

Northumberland County
Capital Improvement Program
2025-2029

DRAFT

Section 1 EMS Department

Section 2 Sanitary District

Section 3 Sheriffs Department

Section 4 School Board

Northumberland County
Capital Improvement Program
2025-2029

Section 1 EMS Department

Northumberland County
Capital Improvement Program
2025-2029

Section 2 EMS Department

Northumberland Department of Emergency Services

Capital Improvement Plan

Northumberland Department of Emergency Services (herein after called department) currently has four (4) Ambulances; (2 front line and 2 reserves), one (1) SUV station vehicle, and 1 (one) Chief vehicle located at the station to conduct the daily business of the department.

Current mileage and inventory of units as of October 2023.

Medic 1; 2021 Ford F450 AEV Ambulance - 27,000 miles

Medic 2; 2021 Ford F450 AEV Ambulance - 34,000 miles

Reserve Medic 1; 2018 F550 Wheel Coach Ambulance – 95,000 miles

Reserve Medic 2; 2017 F550 Wheel Coach Ambulance – 139,000 miles

Response 9 – 2015 Ford Explorer -75,000 miles.

Chief's vehicle – 2020 Ford F150 – 38,000 miles

Current Billing Rates for Northumberland and surrounding localities:

Agency	BLS	ALS	ALS 2	Mileage
Essex	500	600	700	14.00
KQ	550	650	900	13.00
Lancaster	500	650	800	16.00
Northumberland	500	650	750	15.00
Richmond	500	650	750	14.00
Westmoreland	600	750	850	16.00

The current balance in the EMS billing fund is \$600,000.00 as of July 1, 2023. I am estimating an annual billing return of 280,000.00 per year based on the current monthly average of 24,000.00 per month. After the past fiscal year operating budget approval, \$160,000.00 of the \$280,000.00 goes toward capital improvement and \$120,000.00 goes to the EMS budget to offset the impact to the general budget for additional staffing; therefore, you will see the \$160,000.00 as fund deposits in the table.

To plan for the replacement of Ambulances and vehicles, this five-year plan has been developed to coincide with industry best practices. This plan, if approved, would allow the department to maintain an functional, safe, and up-to-standard units for the personnel to operate. This plan does not consider grants that will be applied to offset the cost of the ambulances. If the department is

successful in obtaining grants from the Office of EMS for the ambulance replacement, it would be a 50/50 grant thus reducing the impact to the fund by fifty percent for each ambulance and the Life Pak 15 (LP15).

The department also has two cardiac monitors (Life Pak 15) in its inventory. One unit is three (3) years old and the other is two (2) years old. These units replaced the previous units the department had for seven years according to the department records. The manufacturer recommends a 6-to-8-year life cycle for the unit. Replacement of these units is costly, and I added one replacement to the table to coincide with the previous replacement cycle. The second unit would be replaced in the 2029 fiscal year budget.

Fiscal Year	Fund Balance	Fund Deposits	Expenditures	Balance
2024	\$600,000.00	\$160,000.00	0	\$760,000.00
2025	\$760,000.00	\$160,000.00	\$100,000.00 Replace R-9	\$820,000.00
2026	\$820,000.00	\$160,000.00	\$400,000.00 Replace M2	\$580,000.00
2026	\$580,000.00	\$25,000.00	Sale of Reserve M2	\$605,000.00
2027	\$605,000.00	\$160,000.00	\$50,000 Replace 1 LP 15	\$715,000.00
2028	\$715,000.00	\$160,000.00	\$425,000.00 Replace M1	\$450,000.00
2028	\$450,000.00	\$25,000.00	Sale of Reserve M1	\$475,000.00

Northumberland Emergency Services

Capital Improvement Plan

Response vehicle additional information

#4 The Board of Supervisors approved additional staffing for the department at the beginning of FY24. This additional staffing allows the department to add an EMS supervisor to each shift for improved personnel and department management of the shifts. Providing Advance Life Support for the volunteer agencies is an item the EMS supervisor is also responsible for. The EMS supervisor will utilize this vehicle to conduct their duties which include responding to incidents throughout the county daily. The replacement cycle for this vehicle has been determined utilizing the mileage threshold of the Sheriff's office vehicles to remain consistent.

If this project is not approved for funding, the improvement to the overall EMS system in the county will suffer. Currently when a volunteer agency requests an advanced life support provider it takes an NDES ambulance out of service for the county. This one call now takes two ambulances out of service for the county. By having the EMS supervisor take this position, it allows the NDES ambulance to stay in service for the next call.



Jeff Hawkins
Regional Account Manager
Ambulance Division
Cell (804) 366-9814
jhawkins@atlanticemergency.com

November 2, 2023

Mr. Calvin Balderson, Chief
Northumberland County Department of Emergency Services
72 Monument Place
Heathsville, VA 22473

Re: Wheeled Coach Ambulance Proposal

Chief Balderson,

Atlantic Emergency Solutions, the authorized dealer in Virginia for Wheeled Coach, is pleased to present you with this proposal for one (1) Wheeled Coach Type 1 ambulance built on 2026 Ford F-550 4x4 chassis. This proposal submission includes a detailed work order and drawings. This purchase shall utilize HGAC Contract No. AM10-20 awarded to REV Ambulance Group Orland, Inc.

The pricing listed within this proposal shall be valid until December 31, 2023.

2026 Ford F-550 4x4 / Wheeled Coach Type 1 Ambulance: \$352,113.00

Build Time: Up to 30-34 months from receipt of order

Factory Pickup and Transportation

The completed ambulance shall be shipped via flatbed from Wheeled Coach to Atlantic's Richmond Regional Service Center upon completion.

Dealer Pre-Delivery Inspection and Delivery

Our Richmond Regional Service Center will perform a pre-delivery inspection after delivery from the Wheeled Coach factory. The ambulance shall be delivered to Heathsville, VA upon completion of the pre-delivery inspection.

Fuel, Tags, and State Inspection

Atlantic Emergency Solutions will ensure that the ambulance has a full tank of fuel, temporary 30-day tags, and a valid Virginia State Inspection.

Factory Inspection Trip

The costs for one (1) final inspection trip to the Wheeled Coach factory in Winter Park, Florida to include two (2) Northumberland County personnel per trip are included in the proposal price. This includes commercial airline travel, lodging, meals, and a rental vehicle.

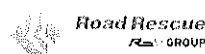



Jeff Hawkins
Regional Account Manager
Ambulance Division
Cell (800) 366-9814
jhawkins@atlanticemergency.com

At Atlantic Emergency Solutions, we have built an internal and external infrastructure capable of meeting the diverse needs of our customers. With 18 service centers and over 20 fully stocked service vehicles located throughout Virginia, North Carolina, Maryland, Delaware, Kentucky, and Ohio our service is unmatched. It is our mission to not only make the duration of your emergency vehicle a pleasant experience, but to assist in any way possible.

Atlantic Emergency Solutions has invested heavily in providing warranty, routine and emergency service to its customers in Virginia. Atlantic Emergency Solutions views the acquisition of custom ambulances by one of our customers not merely a purchase but an investment. This investment needs to be protected with best in local service!

Should you have any additional questions regarding any information in this proposal, please do not hesitate to call or e-mail at the below contact information.

Respectfully submitted,

Jeff Hawkins

A handwritten signature in black ink, appearing to read "Jeff Hawkins", written in a cursive style.

Regional Account Manager
Ambulance Division

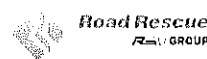

www.atlanticemergency.com (800) 442-9700

Northumberland County Draft Capital Improvement Program Project Form

(1) Office/Department Northumberland Emergency Services			
(2) Project Title Life Pak 15 replacement	Urgent <input type="checkbox"/>	Necessary <input checked="" type="checkbox"/>	Desirable <input type="checkbox"/>
Project Priority Year Required	_____ _____ FY27		
(3) Project Description (include sketches, appraisals, plans, etc.) The Life Pak 15 (LP15) cardiac monitor is one of the most important pieces of equipment we carry on an ambulance. The LP15 is the standard of care device for patient vital signs monitoring, cardiac monitoring, defibrillation, and pacing of critical patients that we may treat.			
Attachment # _____			
(4) Project Justification (includes ramifications if project is not implemented) The LP15 monitor/defibrillator is the epicenter of patient care. The LP15 supports the provider in the monitoring of cardiac rhythm's, blood pressure, and other patient diagnostic measures to allow the provider to make accurate clinical decisions in an emergent setting. The LP15 also supports the EMS clinician in providing the capabilities of defibrillation and pacing during critical cardiac emergencies.			
Attachment # _____			
(5) Cost (include staffing needs, annual O&M requirements, planning/engineering, equipment/furniture, acquisition, construction) Pricing as of January 1, 2023, was \$41,321.32. Compound a product increase of at least 5% over three years and the cost approximately \$50,000.00 for a new unit.			
(6) Funding Source(s)			
Current Revenue _____	Grant (Type) _____	RSAF 50/50 _____	
Revenue Bond _____	Loan (Type) _____	_____	
General Obligation Bond _____	Special Assesment _____	_____	
Capital Reserve Fund _____	Other _____	EMS billing fund _____	
Requestor <u>Calvin Balderson, Jr.</u> Date _____			
Planning Commission Meeting _____ Date/Time _____			
Planning Commission Comments: _____ _____ _____ _____ _____ _____			



NDEMS LIFEPAK 15 2023

Quote Number: 10643787

Remit to: **Stryker Medical**

P.O. Box 93308

Version: 1

Chicago, IL 60673-3308

Prepared For: NORTHUMBERLAND DEPT OF EMER SVCS

Rep: Blair Cooper

Email: elizabeth.cooper@stryker.com

Phone Number: (804) 677-6543

Quote Date: 09/01/2023

Expiration Date: 10/01/2023

Delivery Address

Name: NORTHUMBERLAND DEPT OF EMER SVCS
Account #: 1298791
Address: 195 JUDICIAL PL
HEATHSVILLE
Virginia 22473

End User - Shipping - Billing

Name: NORTHUMBERLAND DEPT OF EMER SVCS
Account #: 1298791
Address: 195 JUDICIAL PL
HEATHSVILLE
Virginia 22473

Bill To Account

Name: NORTHUMBERLAND DEPT OF EMER SVCS
Account #: 1298159
Address: PO BOX 129
HEATHSVILLE
Virginia 22473-0129

Equipment Products:

#	Product	Description	Qty	Sell Price	Total
1.0	99577-001957	LIFEPAK 15 V4 Monitor/Defib - Manual & AED, Trending, Noninvasive Pacing, SpO2, SpCO, NIBP, 12-Lead ECG, EtCO2, BT. Incl at N/C: 2 pr QC Electrodes (11996-000091) & 1 Test Load (21330-001365) per device, 1 Svc Manual CD (26500-003612) per order	1	\$35,129.56	\$35,129.56
2.0	41577-000288	Ship Kit -QUIK-COMBO Therapy Cable; 2 rolls100mm Paper; RC-4, Patient Cable, 4ft.; NIBP Hose, Coiled; NIBP Cuff, Reusable, adult; 12-Lead ECG Cable, 4-Wire Limb Leads, 5ft; 12-Lead ECG Cable, 6-Wire Precordial attachment	1	\$0.00	\$0.00
3.0	11140-000098	LP15 AC Power Adapter (power cord not included)	1	\$2,006.00	\$2,006.00
4.0	11140-000015	AC power cord	1	\$79.52	\$79.52
5.0	11140-000080	Extension Cable (5ft 3 in)	1	\$297.47	\$297.47
6.0	21330-001176	LP 15 Lithium-ion Battery 5.7 amp hrs	1	\$460.44	\$460.44
7.0	11171-000049	Masimo Rainbow DCI Adult Reusable SpO2, SpCO, SpMet Sensor, 3 FT. For use with RC Patient Cable.	1	\$628.32	\$628.32
8.0	11171-000050	Masimo Rainbow DCIP Pediatric Reusable SpO2, SpCO, SpMet Sensor, 3 FT. For use with RC Patient Cable.	1	\$692.13	\$692.13
9.0	11996-000093	Electrode EDGE QUIK-COMBO pediatric RTS	1	\$42.56	\$42.56
10.0	21300-008159	LIFEPAK 15 NIBP Straight Hose, 6'	1	\$85.00	\$85.00
11.0	11160-000011	NIBP Cuff-Reusable, Infant	1	\$20.62	\$20.62
12.0	11160-000013	NIBP Cuff-Reusable, Child	1	\$23.56	\$23.56
13.0	11160-000017	NIBP Cuff -Reusable, Large Adult	1	\$32.40	\$32.40



NDEMS LIFEPAK 15 2023

Quote Number: 10643787

Remit to: **Stryker Medical**

Version: 1

P.O. Box 93308

Chicago, IL 60673-3308

Prepared For: NORTHUMBERLAND DEPT OF EMER SVCS

Rep: Blair Cooper

Email: elizabeth.cooper@stryker.com

Phone Number: (804) 677-6543

Quote Date: 01/30/2023

Expiration Date: 08/01/2023

#	Product	Description	Qty	Sell Price	Total
14.0	11160-000019	NIBP Cuff-Reusable, Adult X Large	1	\$47.12	\$47.12
15.0	11577-000002	LIFEPAK 15 Basic carry case w/right & left pouches; shoulder strap (11577-000001) included at no additional charge when case ordered with a LIFEPAK 15 device	1	\$314.16	\$314.16
16.0	11220-000028	LIFEPAK 15 Carry case top pouch	1	\$55.96	\$55.96
17.0	11260-000039	LIFEPAK 15 Carry case back pouch	1	\$80.50	\$80.50
18.0	21996-000109	Titan III WiFi Gateway	1	\$1,207.00	\$1,207.00
Equipment Total:					\$41,202.32

ProCare Products:

#	Product	Description	Qty	Sell Price	Total
19.0	78000171	LIFENET Asset, per device	1	\$119.00	\$119.00
ProCare Total:					\$119.00

Price Totals:

Grand Total: \$41,321.32

Prices: In effect for 30 days

Terms: Net 30 Days

Contact your local Sales Representative for more information about our flexible payment options.

Capital Terms and Conditions:

Deal Consummation: This is a quote and not a commitment. This quote is subject to final credit, pricing, and documentation approval. Legal documentation must be signed before your equipment can be delivered. Documentation will be provided upon completion of our review process and your selection of a payment schedule. Confidentiality Notice: Recipient will not disclose to any third party the terms of this quote or any other information, including any pricing or discounts, offered to be provided by Stryker to Recipient in connection with this quote, without Stryker's prior written approval, except as may be requested by law or by lawful order of any applicable government agency. A copy of Stryker Medical's Acute Care capital terms and conditions can be found at https://techweb.stryker.com/Terms_Conditions/index.html. A copy of Stryker Medical's Emergency Care capital terms and conditions can be found at <https://www.strykeremergencycare.com/terms>.

Northumberland County Draft Capital Improvement Program Project Form

(1) Office/Department Northumberland Emergency Services											
(2) Project Title Ambulance replacement	Project Priority Year Required	<table border="1" style="width: 100%; border-collapse: collapse;"> <tr> <td style="text-align: center;">Urgent</td> <td style="text-align: center;">Necessary</td> <td style="text-align: center;">Desirable</td> </tr> <tr> <td style="text-align: center;"> </td> <td style="text-align: center;">X</td> <td style="text-align: center;"> </td> </tr> <tr> <td colspan="3" style="text-align: center;">FY28</td> </tr> </table>	Urgent	Necessary	Desirable		X		FY28		
Urgent	Necessary	Desirable									
	X										
FY28											
(3) Project Description (include sketches, appraisals, plans, etc.) Ambulance Replacement -This will be a replacement of the second reserve ambulance in the fleet. This will then become one of the front-line ambulances for response to calls for service. Reserve units are utilized when the primary unit is out of service for maintenance or mechanical problems. Reserve units are also used to provide EMS service to special events allowing the primary units to respond to emergency calls.											
(4) Project Justification (includes ramifications if project is not implemented) This ambulance is a 2018 model and will be 9 years old in FY28. This unit currently has 95,000 miles on the motor and will increase over the next 5 to 6 years. It is standard practice to have a replacement schedule for emergency units to ensure a functional, safe, and up to date unit to provide services to the citizens.											
(5) Cost (include staffing needs, annual O&M requirements, planning/engineering, equipment/furniture, acquisition, construction) \$425,000.00 for the ambulance. Equipment for the unit will be taken from the unit this is replacing.											
(6) Funding Source(s)											
Current Revenue _____ Revenue Bond _____ General Obligation Bond _____ Capital Reserve Fund _____	Grant (Type) _____ Loan (Type) _____ Special Assesment _____ Other _____	RSAF 50/50 _____ _____ _____ EMS billing funds _____									
Requestor <u>Calvin Balderson, Jr.</u> Date _____ Planning Commission Meeting _____ Date/Time _____											
Planning Commission Comments: _____ _____ _____ _____ _____ _____											



Jeff Hawkins
Regional Account Manager
Ambulance Division
Cell (804) 366-9814
jhawkins@atlanticemergency.com

November 2, 2023

Mr. Calvin Balderson, Chief
Northumberland County Department of Emergency Services
72 Monument Place
Heathsville, VA 22473

Re: Wheeled Coach Ambulance Proposal

Chief Balderson,

Atlantic Emergency Solutions, the authorized dealer in Virginia for Wheeled Coach, is pleased to present you with this proposal for one (1) Wheeled Coach Type 1 ambulance built on 2026 Ford F-550 4x4 chassis. This proposal submission includes a detailed work order and drawings. This purchase shall utilize HGAC Contract No. AM10-20 awarded to REV Ambulance Group Orland, Inc.

The pricing listed within this proposal shall be valid until December 31, 2023.

2026 Ford F-550 4x4 / Wheeled Coach Type 1 Ambulance: \$352,113.00

Build Time: Up to 30-34 months from receipt of order

Factory Pickup and Transportation

The completed ambulance shall be shipped via flatbed from Wheeled Coach to Atlantic's Richmond Regional Service Center upon completion.

Dealer Pre-Delivery Inspection and Delivery

Our Richmond Regional Service Center will perform a pre-delivery inspection after delivery from the Wheeled Coach factory. The ambulance shall be delivered to Heathsville, VA upon completion of the pre-delivery inspection.

Fuel, Tags, and State Inspection

Atlantic Emergency Solutions will ensure that the ambulance has a full tank of fuel, temporary 30-day tags, and a valid Virginia State Inspection.

Factory Inspection Trip

The costs for one (1) final inspection trip to the Wheeled Coach factory in Winter Park, Florida to include two (2) Northumberland County personnel per trip are included in the proposal price. This includes commercial airline travel, lodging, meals, and a rental vehicle.

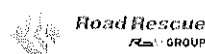



Jeff Hawkins
Regional Account Manager
Ambulance Division
Cell (800) 366-9814
jhawkins@atlanticemergency.com

At Atlantic Emergency Solutions, we have built an internal and external infrastructure capable of meeting the diverse needs of our customers. With 18 service centers and over 20 fully stocked service vehicles located throughout Virginia, North Carolina, Maryland, Delaware, Kentucky, and Ohio our service is unmatched. It is our mission to not only make the duration of your emergency vehicle a pleasant experience, but to assist in any way possible.

Atlantic Emergency Solutions has invested heavily in providing warranty, routine and emergency service to its customers in Virginia. Atlantic Emergency Solutions views the acquisition of custom ambulances by one of our customers not merely a purchase but an investment. This investment needs to be protected with best in local service!

Should you have any additional questions regarding any information in this proposal, please do not hesitate to call or e-mail at the below contact information.

Respectfully submitted,

Jeff Hawkins

A handwritten signature in black ink, appearing to read "Jeff Hawkins", is written over a light gray background.

Regional Account Manager
Ambulance Division

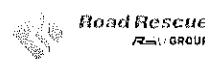

www.atlanticemergency.com (800) 442-9700

Northumberland County
Capital Improvement Program
2025-2029

Section 2 Sanitary District

Northumberland County Sanitary District 5 YEAR CIP

Fiscal Year		Cost/Figure	Project Priority
24-25			
	Krunch Lift Station Generator	\$53,643.00	Urgent
	Callao WWTP Building for Vac-Truck	\$158,400.00	Urgent
	4X4 Truck With Tool Boxes	\$48,381.00	Necessary
25-26			
	Post Office Lift Station Generator	\$53,643.00	Urgent
	Reed/Sutton Gravity Line Project	\$164,500.00	Urgent
	4X4 Truck With Tool Boxes	\$48,381.00	Necessary
26-27			
	Reedville WWTP Building/Maintenance	\$158,400.00	Necessary
	Fleeton Vac Station Upgrade	\$207,379.00	Necessary
27-28			
	Cockrell's Creek Force Main	\$1,627,700.00	Necessary
28-29			
	Blackberry Vac Station Upgrade	\$55,762.00	Necessary

Northumberland County Draft Capital Improvement Program Project Form

(1) Office/Department
Sanitary District

(2) Project Title
Krunch LIFT Station
 Generator Replacement

Urgent	Necessary	Desirable
<input checked="" type="checkbox"/>	<input type="checkbox"/>	<input type="checkbox"/>

Project Priority
 Year Required 24-25

(3) Project Description (include sketches, appraisals, plans, etc.)
Replace 40+ year old generator

Attachment # Estimate #1289

(4) Project Justification (includes ramifications if project is not implemented)
Per DEQ SCAT Regulations. Standby generator is required onsite.

Attachment #

(5) Cost (include staffing needs, annual O&M requirements, planning/engineering, equipment/furniture, acquisition, construction)
\$ 53,643.00

(6) Funding Source(s)

Current Revenue _____	Grant (Type) _____
Revenue Bond _____	Loan (Type) _____
General Obligation Bond _____	Special Assesment _____
Capital Reserve Fund <input checked="" type="checkbox"/>	Other _____

Requestor _____ Date _____

Planning Commission Meeting _____
 Date/Time _____

Planning Commission Comments: _____

Paul A. Ryan, Inc.

5458 Jessie Dupont Mem. Hwy.
 PO Box 473
 Wicomico Church, VA 22579-0473

Estimate

Date	Estimate #
11/6/2023	1289

Name / Address	
Northumberland County 79 Monument Place PO Box 129 Heathsville, VA 22473	
804-580-3217	paularyaninc@gmail.com

P.O. No.	Project
D. Woolard	

Description	Total
<p>Project: Replacement of Crowder Lane pump station standby generator system:</p> <p>Estimate to include:</p> <ul style="list-style-type: none"> - Remove existing generator from building. <p>Generator:</p> <ul style="list-style-type: none"> - Install new 30kW Caterpillar diesel-fueled standby generator set, 120/240Volt 3-phase, 60hz, 1800RPM. - UL2200 certified and NFPA 110 upgraded - Cat C2.2, liter diesel engine, EPA emissions rated stationary/emergency rated - Engine-mounted radiator with coolant - Brushless generator end featuring PMG excitation and anti-condensation heater - SKID-BASED: no diesel fuel tank. - Control Panel: NFPA 110. CAN J139/MODBUS RS485 Communications - Generator run and common alarm relays installed - Circuit breaker (generator mounted): one (1) 100Amp frame (100% rated), LSI adjustable trip, 12Volt shunt trip and auxiliary contacts - Lead acid 12V battery system: battery, racks and cables - Factory mounted UL rated battery charger 10Amp. - Jacket water heater - Five (5) year/ 2500-hour platinum level generator warranty (no deductibles) - Factory 0.8 PF test with report - Standard startup procedures performed during normal business hours. No fuel included. 	
Please contact us with any questions or concerns. Thank you.	Total

Paul A. Ryan, Inc.

5458 Jessie Dupont Mem. Hwy.
 PO Box 473
 Wicomico Church, VA 22579-0473

Estimate

Date	Estimate #
11/6/2023	1289

Name / Address	
Northumberland County 79 Monument Place PO Box 129 Heathsville, VA 22473	
804-580-3217	paularyaninc@gmail.com

P.O. No.	Project
D. Woolard	

Description	Total
<ul style="list-style-type: none"> - Two (2) hour resistive loadbank testing performed during our normal working hours. No fuel included. - Submittals and manuals. - Genset currently has a 14 week lead time. - Relocate existing 200Amp, 240Volt 3-phase, ATS to new Type 1 enclosure separate of pump control equipment. - One (1) 200amp, 240Volt 3-phase NEMA-3R, SER fused disconnect on exterior of building. <p>Related Items not Included:</p> <ul style="list-style-type: none"> - Customer is responsible for diesel fuel needs to generator. <p>Onsite fuel tank to be replaced with new 275 gallon single wall above ground tank. All new conductors to be copper within steel conduits. Existing cooling vents to be reused with new connecting duct as required. Exhaust to vent through wall as required. Equipment and rigging to be provided to convey machine into building.</p>	
Please contact us with any questions or concerns. Thank you.	Total

Paul A. Ryan, Inc.

5458 Jessie Dupont Mem. Hwy.
 PO Box 473
 Wicomico Church, VA 22579-0473

Estimate

Date	Estimate #
11/6/2023	1289

Name / Address	
Northumberland County 79 Monument Place PO Box 129 Heathsville, VA 22473	
804-580-3217	paularyaninc@gmail.com

P.O. No.	Project
D. Woolard	

Description	Total
Materials, labor, and special equipment.	53,643.00
This quote is good for seven (7) days from today. All costs subject to change after 7 days.	
Please contact us with any questions or concerns. Thank you.	Total \$53,643.00

ESTIMATE

Northern Neck Concrete Construction, INC. Tax ID #82-2073193
327 Millwood Lane
Heathsville, VA 22473

genedawson1@gmail.com
804-761-8162

Northumberland County Sanitary District

Bill to
Northumberland County Sanitary District

Estimate details

Estimate no.: 1079
Estimate date: 11/09/2023

#	Product or service	SKU	Qty	Rate	Amount
1.	Sales Estimate for labor & materials on concrete work for pole barn: 40 X 80 with 6 X 80 apron and a 6 X 10 apron				\$37,400.00
2.	Sales Site work The following items will be an additional charge as needed for job: Fill dirt - \$225.00 per load Stone - \$56.00 per ton				\$3,000.00
				Total	\$40,400.00

Note to customer

Thank you for allowing us to provide you with an Estimate on your job. Please note that this is an Estimate, and not an exact quote. We look forward to working with you!

David Woolard

Electrical / HVAC

From: Steven Forrester <sforrester@reid-group.com>
Sent: Thursday, November 9, 2023 7:42 AM
To: David Woolard
Subject: Equipment Building Budget Number

Dave, the budget number for the electric portion of the equipment building at Callao would be \$38,000.00. This could vary either way depending on final design and is subject to ever upward March of material costs.

Thanks, Steve.



Preview Order 9999 - X1L - 4x4 XL SuperCab: Order Summary Time of Preview: 11/04/2023 10:32:13 Receipt: NA

Dealership Name: West Point Ford

Sales Code : F27496

Dealer Rep.	ROBERT CROWTHERIV	Type	Fleet	Vehicle Line	F-150	Order Code	9999
Customer Name	NORTHUMBERLAN	Priority Code	B1	Model Year	2024	Price Level	415

DESCRIPTION	MSRP	DESCRIPTION	MSRP
F150 4X4 SUPERCAB XL - 145	\$44980	3.31 ELECTRONIC LOCK RR AXLE	\$420
145 INCH WHEELBASE	\$0	7100# GVWR PACKAGE	\$0
TOTAL BASE VEHICLE	\$44980	FRONT LICENSE PLATE BRACKET	\$0
OXFORD WHITE	\$0	BLACK PLATFORM RUNNING BOARDS	\$250
VINYL 40/20/40 FRONT SEAT	\$0	50 STATE EMISSIONS	\$0
MEDIUM DARK SLATE	\$0	EXTENDED RANGE 36GAL FUEL TANK	\$0
EQUIPMENT GROUP 101A	\$0	PRICE CONCESSION INDICATOR	\$0
.XL SERIES	\$0	SPECIAL FLEET ACCOUNT CREDIT	\$0
.17" SILVER STEEL WHEELS	\$0	FUEL CHARGE	\$0
5.0L V8 ENGINE	\$1370	PRICED DORA	\$0
ELEC TEN-SPEED AUTO TRANS	\$0	ADVERTISING ASSESSMENT	\$0
.265/70R 17 BSW ALL-TERRAIN	\$0	DESTINATION & DELIVERY	\$1995
TOTAL BASE AND OPTIONS			MSRP \$49015
DISCOUNTS			NA
TOTAL			\$49015

ORDERING FIN: QE754 END USER FIN: QE754
SHIP TO : F27496
18679 Eltham Road, West Point, VA, 23181-9442

INCENTIVES

Acc. Code ID :10 Contract/Ref # :20-99SR Bid Date :09/27/23State : VA Govt. Price Concession

DISCOUNTS: (\$-1600.00)

47,415.00

Customer Name:
Customer Address:

Customer Email:
Customer Phone:

Customer Signature

Date

This order has not been submitted to the order bank.

West Point

Driven By You



Purchase Agreement

Robbie Crowther
West Point Ford
18679 Eltham Road
West Point, VA 23181

Buyer	Co-Buyer	Vehicle
Northumberland County (no name) PO Box 129 Heathsville, VA 22473 C: (804) 724-3002 dwoolard@co.northumberland.va.us		2024 Ford F-150 XL S.C. 4x4 VIN: Stock #: Mileage: Color: white

Customer Trade						
Year	Make	Model	VIN	Engine	Mileage	Payoff
0	0					\$0.00

Term	Cash Down		
	0.00	0.00	0.00
1	Payments		
	\$45,533 to \$45,553	\$45,533 to \$45,553	\$45,533 to \$45,553

Selected Terms	
Loan Term:	1 Monthly
Payment:	\$45,533 to \$45,553

Purchase Details	
Retail Price:	\$49,015.00
Sales Price:	\$45,530.00
Savings:	\$3,485.00
Accessories:	\$0.00
Government Fees:	\$3.00
Proc/Doc Fees:	\$0.00
Total Taxes:	\$0.00
Total Sales Price:	\$45,533.00
Trade Allowance:	\$0.00
Trade Payoff:	\$0.00
Trade Equity:	\$0.00
Rebate:	\$0.00
Cash Down:	\$0.00
Amount Financed:	\$45,533.00

X _____
Customer Signature

Date

X 
Manager Signature

11/4/2023

Date

Disclaimer:

With approved credit. Plus taxes, tags and \$799 processing fee. May require FMCC/LASF financing.

Printed 11/4/23 11:05 AM

9/13/2023

2024 F-150
PRICE LIST
(PRICE LEVEL CODE 415)

PRC

MODEL		SERIES CODE	BASE VEHICLE PRICE	SUGGESTED RETAIL
		F1K	122.5 in. Wheelbase, XL 4x2 RC SS 6.5 Box	
		F1K	141 in. Wheelbase, XL 4x2 RC SS 8.0 Box	
		F1L	122.5 in. Wheelbase, XL 4x4 RC SS 6.5 Box	
		F1L	141 in. Wheelbase, XL 4x4 RC SS 8.0 Box	
		X1K	145 in. Wheelbase, XL 4x2 SC SS 6.5 Box	
		X1L	145 in. Wheelbase, XL 4x4 SC SS 6.5 Box	
		W1K	145 in. Wheelbase, XL 4x2 SCrew SS 5.5 Box	
		W1L	145 in. Wheelbase, XL 4x4 SCrew SS 5.5 Box	
		W1L	157 in. Wheelbase, XL 4x4 SCrew SS 6.5 Box	
		—	Destination and Delivery	1,995
TRIM SERIES	DRIVE	PKG. CODE	PREFERRED EQUIPMENT PACKAGES	SUGGESTED RETAIL
XL	4x2/4x4	101A	Series Price	N/C
		200A	Series Price	N/C
		301A	Series Price	N/C
		401A	Series Price	N/C
		501A	Series Price	N/C
		601A	Series Price	N/C
		701A	Series Price	N/C
		801A	Series Price	N/C
	DRIVE	OPTION CODE	POWERTRAINS	SUGGESTED RETAIL
ENGINE		998	3.5L EcoBoost ilo 2.7L EcoBoost	\$ 1,660
			3.5L EcoBoost ilo 5.0L	290
			3.5L EcoBoost -King ranch and Platinum (701A & 702A)	Std
		995	5.0L V8 -- XL, XLT, Lariat, King Ranch, Platinum, Tremor	Std
			5.0L ilo 2.7L EcoBoost	1,370
		99D	3.5L GTDI HEV ilo 2.7L GTDI	3,560
			3.5L GTDI HEV ilo 5.0L	2,190
			3.5L GTDI HEV ilo 3.5L GTDI	1,900
		99P	2.7L V6 EcoBoost -- XL, STX, XLT	Std
		TRANSMISSION		44G
AXLE		X15	Standard Axle Ratio (where Standard Axle)	Std
		X19	Standard Axle Ratio (where Standard Axle)	Std
		X27	Standard Axle Ratio (where Standard Axle)	Std
		XL3	E-locking 3.31 axle - XL3	\$ 420
			E-locking 3.31 axle - XL3 included w/ 55A	Inc.
		XL9	E-locking 3.55 axle - XL9	470
			E-locking 3.55 axle - XL9 included w/ 53T & 55A	Inc.
		XL6	E-locking 3.73 axle - XL6	570
			E-locking 3.73 axle - XL6 included w/ 53T	Inc.
		XL5	E-locking 3.55 axle (tow/haul pack)	470

PROPRIETARY

STATE
37,114.51
37,389.23
42,342.27
42,616.99
40,734.35
44,216.83
41,864.54
45,622.75
47,080.18
STATE
N/C
N/C
N/C
N/C
N/C
N/C
N/C
N/C
N/C
STATE
1,626.80
284.20
Std
Std
1,342.60
3,488.80
2,146.20
1,862.00
Std
Std
Std
Std
Std
411.60
Inc.
460.60
Inc.
558.60
#VALUE!
460.60

		XL7	E-locking 3.73 axle (tow/haul pack)	570
	OPTION CODE	OTHER OPTIONS (continued)		SUGGESTED RETAIL
AVAILABLE ON ALL MODELS UNLESS OTHERWISE NOTED	103A	Equipment Group 103A (XL High)		1,000
	U99	HEV Discount		(1,900)
	T7C	LT265/70R17C BSW all-terrain tires (A/T) – Fleet		295
	T8C	LT265/70R18C BSW all-terrain tires (A/T)		295
	53T	Tow/Hall Package (XL)		785
	477	Black Platform Running Boards - XL		250
	924	Rear-Window, Fixed Privacy Glass with Defroster - XL		100
	88A	Vinyl 40/20/40 Front-Seat - XL		N/C
	67T	Integrated Trailer Brake Controller - XL, STX, XLT		275
	PD4	Rapid Red Metallic Tinted Clearcoat		495
	PAZ	Star White Metallic Tri-Coat		995
	942	Daytime running lights - Fleet		45
	AVAILABLE ON ALL MODELS UNLESS OTHERWISE NOTED	41H	Engine Block Heater	
91P		POWER 8-WAY DRIVER SEAT ADJUST - Fleet		350
47R		All-Weather Rubber Floor Mats		200
16G		Vinyl Flooring – Black - Fleet		N/C
96P		Bedliner – Plastic drop-in		350
96W		Bedliner – Tough Bed® spray-in		595
96L		Wheel Well Liner		180
153		Front License Plate Bracket		N/C
PGR		Paint, Green (Fleet Only)		660
PMB		Paint, Orange (Fleet Only)		660
PB1		Paint, School Bus Yellow (Fleet Only)		660
PE4		Paint, Vermillion Red (Fleet Only)		660
PAT		Paint, Yellow (Fleet Only)		660
59S		LED Sideview mirror Spotlights		175
413		Skid Plates (Fleet only)		160
95K		Hero Card - School Bus Yellow / Black Hood		165
96T		Tonneau Pickup Box Cover – Soft Folding		590
96X		Tonneau Pickup Box Cover – Hard Folding		1,200
96J		Tonneau Pickup Box Cover – Retractable		2,200
66C		Paint Protection Film		400
66B		Retractable Rear Center Step		430
90B		Aluminum Crossbed Toolbox by Weather Guard – Matte Black		950
90P		Aluminum Crossbed Toolbox by Weather Guard – Bright		950
85H		Backup Alarm		220
94S		360° LED Warning Beacons – Amber – Fleet Only		650
94W	360° LED Warning Beacons – Amber / White – Fleet Only		650	

558.60
STATE
980.00
(1,862.00)
289.10
289.10
769.30
245.00
98.00
N/C
269.50
485.10
975.10
44.10
88.20
343.00
196.00
N/C
343.00
583.10
176.40
N/C
646.80
546.80
646.80
646.80
646.80
171.50
156.80
161.70
678.20
1,176.00
2,156.00
392.00
421.40
931.00
931.00
215.80
637.00
637.00

Search 

Gloucester Lowe's Open until 9 PM

Delh 230€



Prices, Promotions, styles, and availability may vary. Our local stores do not honor online pricing. Prices and availability of products and services subject to change without notice. Errors will be corrected where discovered, and Lowe's reserves the right to revoke any stated offer and to correct any errors, inaccuracies or omissions including after an order has been submitted.

Automotive / Cargo Management / Truck Tool Boxes

WEATHER GUARD 72-in x 20.5-in 20.5-in x 18.5-in Textured Matte Black Aluminum Crossover Truck Tool Box

Item #4768925 | Model #121-52-03

Shop WEATHER GUARD  13

-
-
-
-
-
-
-
-
-
-
-
-
-
-
-
-
-
-
-
-





\$966.00 | ~~\$994.00~~
Save \$28.09

 **\$917.70** when you choose 5% savings on eligible purchases every day. [Learn how](#) **OR** **\$161/mo** suggested payments with 6 month special financing. [Learn how](#)

 12 monthly installments of \$87.19 with Lowe's Pay [Learn How](#)

Most popular truck storage solution due to ease of installation, maximum bed clearance, and legendary durability
Code multiple boxes on a truck or entire fleet to the same key with new code-able push button lock
Tamper resistant push button lock helps protect against break-ins

Manufacturer Color/Finish: Textured Matte Black

\$966.00 Out of Stock 5966.00 Out of Stock

Pickup
Ready by Mon, Nov 20 (Est.)

Delivery
As soon as Sun, Nov 19

 FREE Pickup at Gloucester Lowe's

1 +

 **Easy & Free Returns**
Return your new, unused item in-store or ship it back to us free of charge. [Learn More](#)

WEATHER GUARD 72-in x 20.5-in 20.5-in x 18.5-in Textured Matte Black Aluminum Crossover Truck Tool Box **\$966.00**

Shop WEATHER GUARD  13

BETTER TOGETHER



Paul A. Ryan, Inc.

5458 Jessie Dupont Mem. Hwy.
 PO Box 473
 Wicomico Church, VA 22579-0473

Estimate

Date	Estimate #
11/6/2023	1290

Name / Address	
Northumberland County 79 Monument Place PO Box 129 Heathsville, VA 22473	
804-580-3217	paularyaninc@gmail.com

P.O. No.	Project
D. Woolard	

Description	Total
<p>Project: Replacement of Post Office Pump Station standby generator system:</p> <p>Estimate to include:</p> <ul style="list-style-type: none"> - Remove existing generator from building. <p>Generator:</p> <ul style="list-style-type: none"> - Install new 30kW Caterpillar diesel-fueled standby generator set, 120/240Volt 3-phase, 60hz, 1800RPM. - UL2200 certified and NFPA 110 upgraded - Cat C2.2, liter diesel engine, EPA emissions rated stationary/emergency rated - Engine-mounted radiator with coolant - Brushless generator end featuring PMG excitation and anti-condensation heater - SKID-BASED: no diesel fuel tank. - Control Panel: NFPA 110. CAN J139/MODBUS RS485 Communications - Generator run and common alarm relays installed - Circuit breaker (generator mounted): one (1) 100Amp frame (100% rated), LSI adjustable trip, 12Volt shunt trip and auxiliary contacts - Lead acid 12V battery system: battery, racks and cables - Factory mounted UL rated battery charger 10Amp. - Jacket water heater - Five (5) year/ 2500-hour platinum level generator warranty (no deductibles) - Factory 0.8 PF test with report - Standard startup procedures performed during normal business hours. No fuel included. 	
Please contact us with any questions or concerns. Thank you.	Total

Paul A. Ryan, Inc.

5458 Jessie Dupont Mem. Hwy.
 PO Box 473
 Wicomico Church, VA 22579-0473

Estimate

Date	Estimate #
11/6/2023	1290

Name / Address	
Northumberland County 79 Monument Place PO Box 129 Heathsville, VA 22473	
804-580-3217	paularyaninc@gmail.com

P.O. No.	Project
D. Woolard	

Description	Total
<ul style="list-style-type: none"> - Two (2) hour resistive loadbank testing performed during our normal working hours. No fuel included. - Submittals and manuals. - Genset currently has a 14 week lead time. - Relocate existing 200Amp, 240Volt 3-phase, ATS to new Type 1 enclosure separate of pump control equipment. - One (1) 200amp, 240Volt 3-phase NEMA-3R, SER fused disconnect on exterior of building. <p>Related Items not Included:</p> <ul style="list-style-type: none"> - Customer is responsible for diesel fuel needs to generator. <p>Onsite fuel tank to be replaced with new 275 gallon single wall above ground tank. All new conductors to be copper within steel conduits. Existing cooling vents to be reused with new connecting duct as required. Exhaust to vent through wall as required. Equipment and rigging to be provided to convey machine into building.</p>	
Please contact us with any questions or concerns. Thank you.	Total

Paul A. Ryan, Inc.

5458 Jessie Dupont Mem. Hwy.
 PO Box 473
 Wicomico Church, VA 22579-0473

Estimate

Date	Estimate #
11/6/2023	1290

Name / Address	
Northumberland County 79 Monument Place PO Box 129 Heathsville, VA 22473	
804-580-3217	paularyaninc@gmail.com

P.O. No.	Project
D. Woolard	

Description	Total
Materials, labor, and special equipment.	53,643.00
This quote is good for seven (7) days from today. All costs subject to change after 7 days.	
Please contact us with any questions or concerns. Thank you.	Total \$53,643.00

Reed / Morrison Line Replacement

The Northumberland County Sanitary District is looking to have a section of sewer line in the area of Reed Avenue and Morrison Avenue in Reedville, Va. This section of line has been problematic and is in an area that is nearly inaccessible.

This area of sewer line, which crosses private property, travels through a marshy area on the edge of a creek and is extremely difficult to get to on foot much less with equipment. The Sanitary District has had several issues with blockages and infiltration in this section of line in the past and have had this line inspected with camera. There is also a manhole which is located in the marsh and currently allows daily seepage and higher levels of infiltration during higher tides.

November 12, 2023

David B. Woolard
 Sanitary District Supervisor
 Northumberland County
 PO Box 129
 Heathsville, Virginia 22473

RE: Letter Proposal for Permitting and Detailed Engineering for Re-Routing Reed Avenue Gravity Sewer to Kelly Pump Station

Thank you for the opportunity to submit a proposal to work with you and your staff on this important project.

This letter proposal presents a scope of work for the development and submission of permitting documents to DEQ and detailed design services to produce bid-ready documents to re-route a segment of the Reed Avenue 8-inch gravity sewer (~ 200 LF) and a new 8-inch gravity sewer (~ 358 LF) along Morris Street and an existing ROW/easement to the Kelly Pump Station.

Opinion of Probable Construction Costs

Based upon experience with similar projects a Planning-Level Engineer's Opinion of Probable Construction Cost range is \$90,000 to \$130,000 (Nov 2023 basis).

Schedule:

Detailed Design can be performed concurrent with permitting, with a duration of three (3) months upon notice to proceed.

Compensation: The services outlined above will be performed on a lump sum basis. The fee was based on the categories and hours itemized below. Invoices will be submitted monthly.

Survey and Permitting		
Project Manager-Engineer	40 hours @ \$140/hr	\$ 5,600
CAD	20 hours @ \$95/hr	\$ 1,900
Survey & Easement along Morris St.		\$12,000
 Design & Bid Phase Services		
Project Manager-Engineer	80 hours @ \$140/hr	\$11,200
CAD	40 hours @ \$95/hr	\$ 3,800
Total		\$34,500

November 12, 2023

Page 2 of 2

Northumberland County

By: _____

Title:

Date Signed: _____

Address for giving notices

PO Box 129
Heathsville Va 22473

Mangrum Consulting & Design



By: Rob Mangrum, P.E., BCEE

Title: President

Date Signed: 11/12/2023

Address for giving notices:

1500 Clayton Avenue
Lynchburg, Virginia 24503



Preview Order 9999 - X1L - 4x4 XL SuperCab: Order Summary Time of Preview: 11/04/2023 10:32:13 Receipt: NA

Dealership Name: West Point Ford

Sales Code : F27496

Dealer Rep.	ROBERT CROWTHERIV	Type	Fleet	Vehicle Line	F-150	Order Code	9999
Customer Name	NORTHUMBERLAN	Priority Code	B1	Model Year	2024	Price Level	415

DESCRIPTION	MSRP	DESCRIPTION	MSRP
F150 4X4 SUPERCAB XL - 145	\$44980	3.31 ELECTRONIC LOCK RR AXLE	\$420
145 INCH WHEELBASE	\$0	7100# GVWR PACKAGE	\$0
TOTAL BASE VEHICLE	\$44980	FRONT LICENSE PLATE BRACKET	\$0
OXFORD WHITE	\$0	BLACK PLATFORM RUNNING BOARDS	\$250
VINYL 40/20/40 FRONT SEAT	\$0	50 STATE EMISSIONS	\$0
MEDIUM DARK SLATE	\$0	EXTENDED RANGE 36GAL FUEL TANK	\$0
EQUIPMENT GROUP 101A	\$0	PRICE CONCESSION INDICATOR	\$0
.XL SERIES	\$0	SPECIAL FLEET ACCOUNT CREDIT	\$0
.17" SILVER STEEL WHEELS	\$0	FUEL CHARGE	\$0
5.0L V8 ENGINE	\$1370	PRICED DORA	\$0
ELEC TEN-SPEED AUTO TRANS	\$0	ADVERTISING ASSESSMENT	\$0
.265/70R 17 BSW ALL-TERRAIN	\$0	DESTINATION & DELIVERY	\$1995
TOTAL BASE AND OPTIONS			MSRP \$49015
DISCOUNTS			NA
TOTAL			\$49015

ORDERING FIN: QE754 END USER FIN: QE754
SHIP TO : F27496
18679 Eltham Road, West Point, VA, 23181-9442

INCENTIVES

Acc. Code ID :10 Contract/Ref # :20-995R Bid Date :09/27/23State : VA *Govt. Price Concession*

DISCOUNTS:
(\$-1600.00)

\$ 47,415.00

Customer Name:
Customer Address:

Customer Email:

Customer Phone:

Customer Signature

Date

This order has not been submitted to the order bank.

West Point

Driven By You



Purchase Agreement

Robbie Crowther
West Point Ford
18679 Eltham Road
West Point, VA 23181

Buyer	Co-Buyer	Vehicle
Northumberland County (no name) PO Box 129 Heathsville, VA 22473 C: (804) 724-3002 dwoolard@co.northumberland.va.us		2024 Ford F-150 XL S.C. 4X4 VIN: Stock #: Mileage: Color: <i>White</i>

Customer Trade							
	Year	Make	Model	VIN	Engine	Mileage	Payoff
0	0						\$0.00

Cash Down			
	0.00	0.00	0.00
Term	Payments		
1	\$45,533 to \$45,553	\$45,533 to \$45,553	\$45,533 to \$45,553

Selected Terms	
Loan Term:	1 Monthly
Payment:	\$45,533 to \$45,553

Purchase Details	
Retail Price:	\$49,015.00
Sales Price:	\$45,530.00
Savings:	\$3,485.00
Accessories:	\$0.00
Government Fees:	\$3.00
Proc/Doc Fees:	\$0.00
Total Taxes:	\$0.00
Total Sales Price:	\$45,533.00
Trade Allowance:	\$0.00
Trade Payoff:	\$0.00
Trade Equity:	\$0.00
Rebate:	\$0.00
Cash Down:	\$0.00
Amount Financed:	\$45,533.00

X

Customer Signature

Date

X

Manager Signature

Date

Disclaimer:

Printed 11/4/23 11:05 AM

With approved credit. Plus taxes, tags and \$799 processing fee. May require FMCC/LASF financing.

9/13/2023

2024 F-150
PRICE LIST
 (PRICE LEVEL CODE 415)

PRC

MODEL		SERIES CODE	BASE VEHICLE PRICE	SUGGESTED RETAIL
		F1K	122.5 in. Wheelbase, XL 4x2 RC SS 6.5 Box	
		F1K	141 in. Wheelbase, XL 4x2 RC SS 8.0 Box	
		F1L	122.5 in. Wheelbase, XL 4x4 RC SS 6.5 Box	
		F1L	141 in. Wheelbase, XL 4x4 RC SS 8.0 Box	
		X1K	145 in. Wheelbase, XL 4x2 SC SS 6.5 Box	
		X1L	145 in. Wheelbase, XL 4x4 SC SS 6.5 Box	
		W1K	145 in. Wheelbase, XL 4x2 SCrew SS 5.5 Box	
		W1L	145 in. Wheelbase, XL 4x4 SCrew SS 5.5 Box	
		W1L	157 in. Wheelbase, XL 4x4 SCrew SS 6.5 Box	
		—	Destination and Delivery	1,995
TRIM SERIES	DRIVE	PKG. CODE	PREFERRED EQUIPMENT PACKAGES	SUGGESTED RETAIL
XL	4x2/4x4	101A	Series Price	N/C
		200A	Series Price	N/C
		301A	Series Price	N/C
		401A	Series Price	N/C
		501A	Series Price	N/C
		601A	Series Price	N/C
		701A	Series Price	N/C
		801A	Series Price	N/C
	DRIVE	OPTION CODE	POWERTRAINS	SUGGESTED RETAIL
ENGINE		998	3.5L EcoBoost ilo 2.7L EcoBoost	\$ 1,660
			3.5L EcoBoost ilo 5.0L	290
			3.5L EcoBoost -King ranch and Platinum (701A & 702A)	Std
		995	5.0L V8 -- XL, XLT, Lariat, King Ranch, Platinum, Tremor	Std
			5.0L ilo 2.7L EcoBoost	1,370
		99D	3.5L GTDI HEV ilo 2.7L GTDI	3,560
			3.5L GTDI HEV ilo 5.0L	2,190
			3.5L GTDI HEV ilo 3.5L GTDI	1,900
		99P	2.7L V6 EcoBoost -- XL, STX, XLT	Std
		TRANSMISSION		44G
AXLE		X15	Standard Axle Ratio (where Standard Axle)	Std
		X19	Standard Axle Ratio (where Standard Axle)	Std
		X27	Standard Axle Ratio (where Standard Axle)	Std
		XL3	E-locking 3.31 axle - XL3	\$ 420
			E-locking 3.31 axle - XL3 included w/ 55A	Inc.
		XL9	E-locking 3.55 axle - XL9	470
			E-locking 3.55 axle - XL9 included w/ 53T & 55A	Inc.
		XL6	E-locking 3.73 axle - XL6	570
			E-locking 3.73 axle - XL6 included w/ 53T	Inc.
		XL5	E-locking 3.55 axle (tow/haul pack)	470

PROPRIETARY

STATE
37,114.51
37,389.23
42,342.27
42,616.99
40,734.35
44,216.83
41,864.54
45,622.75
47,080.18
STATE
N/C
N/C
N/C
N/C
N/C
N/C
N/C
N/C
N/C
STATE
1,626.80
284.20
Std
Std
1,342.60
3,488.80
2,146.20
1,862.00
Std
Std
Std
Std
Std
411.60
Inc.
460.60
Inc.
558.60
#VALUE!
460.60

		XL7	E-locking 3.73 axle (tow/haul pack)	570
	OPTION CODE	OTHER OPTIONS (continued)		SUGGESTED RETAIL
AVAILABLE ON ALL MODELS UNLESS OTHERWISE NOTED	103A	Equipment Group 103A (XL High)		1,000
	U99	HEV Discount		(1,900)
	T7C	LT265/70R17C BSW all-terrain tires (A/T) – Fleet		295
	T8C	LT265/70R18C BSW all-terrain tires (A/T)		295
	53T	Tow/Hall Package (XL)		785
	477	Black Platform Running Boards - XL		250
	924	Rear-Window, Fixed Privacy Glass with Defroster - XL		100
	88A	Vinyl 40/20/40 Front-Seat - XL		N/C
	67T	Integrated Trailer Brake Controller - XL, STX, XLT		275
	PD4	Rapid Red Metallic Tinted Clearcoat		495
	PAZ	Star White Metallic Tri-Coat		995
	942	Daytime running lights - Fleet		45
	AVAILABLE ON ALL MODELS UNLESS OTHERWISE NOTED	41H	Engine Block Heater	
91P		POWER 8-WAY DRIVER SEAT ADJUST - Fleet		350
47R		All-Weather Rubber Floor Mats		200
16G		Vinyl Flooring – Black - Fleet		N/C
96P		Bedliner – Plastic drop-in		350
96W		Bedliner – Tough Bed® spray-in		595
96L		Wheel Well Liner		180
153		Front License Plate Bracket		N/C
PGR		Paint, Green (Fleet Only)		660
PMB		Paint, Orange (Fleet Only)		660
PB1		Paint, School Bus Yellow (Fleet Only)		660
PE4		Paint, Vermillion Red (Fleet Only)		660
PAT		Paint, Yellow (Fleet Only)		660
59S		LED Sideview mirror Spotlights		175
413		Skid Plates (Fleet only)		160
95K		Hero Card - School Bus Yellow / Black Hood		165
96T		Tonneau Pickup Box Cover – Soft Folding		590
96X		Tonneau Pickup Box Cover – Hard Folding		1,200
96J		Tonneau Pickup Box Cover – Retractable		2,200
66C		Paint Protection Film		400
66B		Retractable Rear Center Step		430
90B		Aluminum Crossbed Toolbox by Weather Guard – Matte Black		950
90P		Aluminum Crossbed Toolbox by Weather Guard – Bright		950
85H		Backup Alarm		220
94S		360° LED Warning Beacons – Amber – Fleet Only		650
94W		360° LED Warning Beacons – Amber / White – Fleet Only		650

558.60
STATE
980.00
(1,862.00)
289.10
289.10
769.30
245.00
98.00
N/C
269.50
485.10
975.10
44.10
88.20
343.00
196.00
N/C
343.00
583.10
176.40
N/C
646.80
646.80
646.80
646.80
646.80
171.50
156.80
161.70
578.20
1,176.00
2,156.00
392.00
421.40
931.00
931.00
215.60
637.00
637.00

Search

Gloucester Lowe's Open until 9 PM

Deliv 2306



Prices, Promotions, styles, and availability may vary. Our local stores do not honor online pricing. Prices and availability of products and service subject to change without notice. Errors will be corrected where discovered, and Lowe's reserves the right to revoke any stated offer and to correct any errors, inaccuracies or omissions including after an order has been submitted.

Automotive / Cargo Management / Truck Tool Boxes

WEATHER GUARD 72-in x 20.5-in 20.5-in x 18.5-in Textured Matte Black Aluminum Crossover Truck Tool Box

Item #4768925 | Model #121-52-03

Shop WEATHER GUARD 13

- Vertical list of 13 small circular icons representing product variants.



\$966.00 ~~\$994.09~~ Save \$28.09

\$917.70 when you choose 5% savings on eligible purchases every day. OR \$161/mo suggested payments with 6 month special financing. Learn how

Lowe's Pay 12 monthly instalments of \$87.19 with Lowe's Pay Learn How

Most popular truck storage solution due to ease of installation, maximum bed clearance, and legendary durability. Code multiple boxes on a truck or entire fleet to the same key with new code-able push button lock. Tamper resistant push button lock helps protect against break-ins

Manufacturer Color/Finish: Textured Matte Black

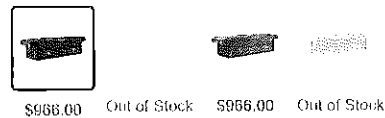

Pickup Ready by Mon, Nov 20 (Est.)

Delivery As soon as Sun, Nov 19

FREE Pickup at Gloucester Lowe's

Quantity selector: 1 + Add to cart

Easy & Free Returns Return your new, unused item in-store or ship it back to us free of charge. Learn More

WEATHER GUARD 72-in x 20.5-in 20.5-in x 18.5-in Textured Matte Black Aluminum Crossover Truck Tool Box \$966.00

Shop WEATHER GUARD 13

BETTER TOGETHER



ESTIMATE

Northern Neck Concrete genedawson1@gmail.com
Construction, INC. Tax ID #82- 804-761-8162
2073193
327 Millwood Lane
Heathsville, VA 22473

Northumberland County Sanitary District

Bill to
Northumberland County Sanitary District

Estimate details
Estimate no.: 1079
Estimate date: 11/09/2023

#	Product or service	SKU	Qty	Rate	Amount
1.	Sales Estimate for labor & materials on concrete work for pole barn: 40 X 80 with 6 X 80 apron and a 6 X 10 apron				\$37,400.00
2.	Sales Site work The following items will be an additional charge as needed for job: Fill dirt - \$225.00 per load Stone - \$56.00 per ton				\$3,000.00
				Total	\$40,400.00

Note to customer

Thank you for allowing us to provide you with an Estimate on your job. Please note that this is an Estimate, and not an exact quote. We look forward to working with you!

David Woolard

Electrical / HVAC

From: Steven Forrester <sforrester@reid-group.com>
Sent: Thursday, November 9, 2023 7:42 AM
To: David Woolard
Subject: Equipment Building Budget Number

Dave, the budget number for the electric portion of the equipment building at Callao would be \$38,000.00. This could vary either way depending on final design and is subject to ever upward March of material costs.

Thanks, Steve.

Northumberland County Draft Capital Improvement Program Project Form

(1) Office/Department Sanitary District			
(2) Project Title Fleeton Vacuum Station Upgrades	Project Priority Year Required	Urgent <input type="checkbox"/>	Necessary <input checked="" type="checkbox"/>
		Desirable <input type="checkbox"/>	26-27
(3) Project Description (include sketches, appraisals, plans, etc.) Upgrade 21 year old station - working equipment - vacuum pumps, motor starters and other related equipment			
Attachment # (1)			
(4) Project Justification (includes ramifications if project is not implemented) Equipment is well aged and end of shelf life. These vacuum pumps are a high demand for our vacuum system to operate and function correctly. Improve energy consumption which would provide dividends			
(5) Cost (include staffing needs, annual O&M requirements, planning/engineering, equipment/furniture, acquisition, construction) See attachment \$ 207,379.00 MINK PUMPS \$135,760.00 LABOR/INSTALL \$71,619.00			
(6) Funding Source(s)			
Current Revenue	_____	Grant (Type)	_____
Revenue Bond	_____	Loan (Type)	_____
General Obligation Bond	_____	Special Assesment	_____
Capital Reserve Fund	<input checked="" type="checkbox"/>	Other	_____
Requestor _____		Date _____	
		Planning Commission Meeting _____ Date/Time _____	
Planning Commission Comments: _____ _____ _____ _____ _____ _____			

POWER & FLOW SOLUTIONS, LLC

P.O. Box 6276 Ashland, VA 23005
Phone: 804-798-2051 Fax: 804-798-2052

Quote # 231411

Date 11/14/23

Northumberland County
Attention: Mr. David Woolard
P.O. Box 129
Heathsville, VA 22473

Phone: 804-724-3002
Fax:

RE: Fleeton Pump Station Upgrades

We propose to furnish all labor, transportation, materials, and equipment to supply and install the following:

Fleeton Pump Station Upgrades

- Four (4) Busch Mink MM1502AV 15HP vacuum pumps.
- Four (4) 15 HP 480V 3PH open chassis VFDs
- Flanged pipe and valves required to add the proposed 4th vacuum pump to include one (1) isolation butterfly valve and one (1) flanged check valve.
- Install new circuit to power proposed 4th vacuum pump.
- Add four (4) din rail mount breakers in existing control panel to feed proposed VFDs.
- One (1) 30A 3P 600V rotary disconnect switch NEMA 3R enclosure.
- One (1) 30 PSI to -30Hg pressure transducer.
- One (1) 3" flanged inlet filter with clear housing.
- Replace (2) starters for 10HP 480V 3PH sewage pumps.
- One (1) 30A 3P 600V rotary disconnect switch NEMA 3R enclosure.

For the estimated sum of.....\$207,379.00

This proposal is based upon the following conditions:

- Work may be performed during normal working hours. Monday through Friday 7:00 am - 7:00 pm
- Suitable access to the site for vehicles and equipment.
- Work is intended to be performed with minimal shutdowns. Any required shutdowns will be coordinated with County personnel.

This proposal excludes the following:

- Metering
- Bonds
- Permits
- Landscaping or fencing
- Rock or obstruction excavation and offsite disposal
- Site work, excavation, or fine grading
- Temporary or permanent seeding or mulching
- Erosion and sediment controls and/or maintenance of such
- Surveying and stake out for waterlines or buildings
- Locating and marking of private utilities onsite
- Support, location, protection or relocation of any existing utilities
- Clearing and disposal of any trees
- Handling or disposing of any hazardous materials and / or contaminated waste
- Geotechnical services to include soils, concrete, and compaction testing
- Undercut of soft or yielding subgrade and replacement fill material
- Temporary seeding or mulching
- Aerating, plowing or disking of soils to obtain optimum moisture content for compaction efforts
- Import of "select" soils for trench backfill if existing soils are deemed unsuitable
- Any work outside of the limits of construction, work not specifically shown on the plans or work not described in the specifications as referenced to above.

The above prices expire in 30 days.

Payment terms are as follows:

Terms are net due and payable within 30 days of completion. If the project exceeds one month, progress payments will be submitted by the 25th of each month and due according to the above terms until final completion. If you have any questions or require further assistance please call Bryan McCaleb at 804-798-2051. Thank you for the opportunity.

Offered By: _____ Title _____ Date _____

Accepted By: _____ Title _____ Date _____

POWER & FLOW SOLUTIONS, LLC

P.O. Box 6276 Ashland, VA 23005

Phone: 804-798-2051 Fax: 804-798-2052

Quote # 231411

Date 11/14/23

Northumberland County
Attention: Mr. David Woolard
P.O. Box 129
Heathsville, VA 22473

Phone: 804-724-3002
Fax:

RE: Blackberry Pump Station Upgrades

We propose to furnish all labor, transportation, materials, and equipment to supply and install the following:

Blackberry Pump Station Upgrades

- Remove two (2) existing 15 HP vacuum pumps at Blackberry Pump Station and replace them with two (2) used 25 HP vacuum pumps from Fleeton Pump Station.
- Associated piping as required for pump installation.
- Two (2) IEC starters 25HP 230V 3PH.
- New GRS conduit and wire runs for each pump.
- Replace two (2) existing 4" suction plug valves with 4" flanged gate valves.
- Replace two (2) existing 4" discharge plug valves with 4" flanged gate valves.
- Replace one (1) existing 4" plug valve in main discharge line with 4" flanged gate valve.
- Replace one (1) existing 4" flanged swing check valve in main discharge line.
- One (1) ABB C1300 chart recorder (paper and pens as required ordered separately).
- One (1) pressure transducer 30 PSI to -30 Hg. Existing DPM will be used to process 4-20ma signal from proposed transducer.
- Two (2) 3" flanged inlet filters with clear housing.

For the estimated sum of.....\$44,590.00

This proposal is based upon the following conditions:

- Work may be performed during normal working hours. Monday through Friday 7:00 am - 7:00 pm
- Suitable access to the site for vehicles and equipment.
- Work is intended to be performed with minimal shutdowns. Any required shutdowns will be coordinated with County personnel.

This proposal excludes the following:

- Metering
- Bonds
- Permits
- Landscaping or fencing
- Rock or obstruction excavation and offsite disposal
- Site work, excavation, or fine grading
- Temporary or permanent seeding or mulching
- Erosion and sediment controls and/or maintenance of such
- Surveying and stake out for waterlines or buildings
- Locating and marking of private utilities onsite
- Support, location, protection or relocation of any existing utilities
- Clearing and disposal of any trees
- Handling or disposing of any hazardous materials and / or contaminated waste
- Geotechnical services to include soils, concrete, and compaction testing
- Undercut of soft or yielding subgrade and replacement fill material
- Temporary seeding or mulching
- Aerating, plowing or disking of soils to obtain optimum moisture content for compaction efforts
- Import of "select" soils for trench backfill if existing soils are deemed unsuitable
- Any work outside of the limits of construction, work not specifically shown on the plans or work not described in the specifications as referenced to above.

The above prices expire in 30 days.

Payment terms are as follows:

Terms are net due and payable within 30 days of completion. If the project exceeds one month, progress payments will be submitted by the 25th of each month and due according to the above terms until final completion. If you have any questions or require further assistance please call Bryan McCaleb at 804-798-2051. Thank you for the opportunity.

Offered By: _____ Title _____ Date _____

Accepted By: _____ Title _____ Date _____

Airvac, Inc.
 4217 N. Old US Highway 31
 Rochester, IN 46975
 Tel# 574.223.3980
 Tax ID#:35-2749561

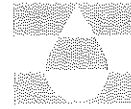

Airvac

Sold-to address
 Northumberland County (SP)
 PO Box 129
 Heathsville VA 22473

Ship-to address
 Reedsville Sanitary Dist
 152 Menhaden Road
 Reedsville VA 22539

Quotation
Number/Date 20127200 / 10/24/2023
Reference no./Date
Sold-To 10000791
Validity period 10/24/2023 to 11/24/2023
Sales person name Mid Atlantic
Entered by Becky Murphy

We deliver according to the following conditions:
 Currency USD
 Terms of payment: Within 30 days without deduction
 Terms of delivery: CIP Reedsville, VA

THIS IS NOT A BILL

US13REE01P01
 *freight not in quote, to be added when invoiced

Item	Material Description	Qty	UoM	Price	Value
000010	EAAC-KIT5 REMOTE MOUNT SOLAR EAAC KIT	1.000	EA	5,586.00 USD	5,586.00
Items total					5,586.00
Tax Jur Code Level 1		0.000	%	5,586.00	0.00
Final amount					5,586.00

(2)-total

11,172.00

Airvac, Inc., on behalf of its designated affiliates and subsidiaries (such term shall include any subsidiary, division or affiliate of Airvac, Inc. as designated (hereinafter Airvac)) will furnish requested equipment, materials or service (hereinafter Goods) to buyer. Such provision shall be governed by Airvac's terms and conditions published at: www.airvac.com/en/terms-and-conditions and/or that are forwarded with the order request (hereinafter Terms). These Terms shall control and govern all transactions between Buyer and Airvac, whether under subsequent verbal and/or written requests, unless subject to an express, duly executed agreement which is not a pre-printed form for the particular subject matter effective either upon buyer signing the Terms or order confirmation or quote, or upon Airvac shipping the Goods or otherwise commencing performance, whichever occurs first. The Terms, together with the specifications, drawings and other requirements specified, constitutes the entire agreement between the parties, and all prior negotiations are proposals related thereto are superseded and of no effect. Any written confirmation by buyer containing additional or different terms from the Terms shall be of no effect, unless Airvac expressly agrees, in writing, to such additional or different terms.

Northumberland County
Capital Improvement Program
2025-2029

Section 3 Sheriff's Department

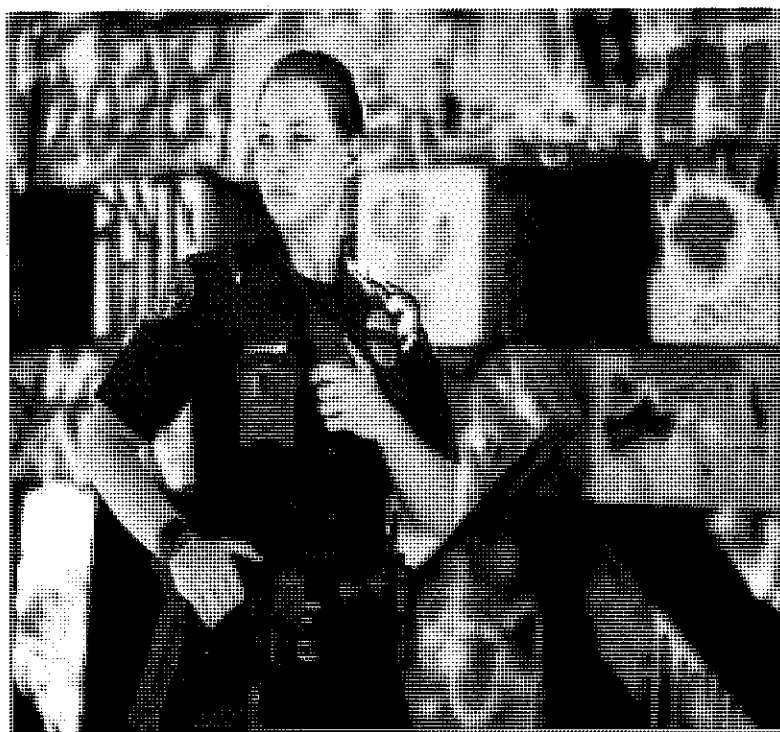

NORTHUMBERLAND COUNTY SHERIFF'S DEPARTMENT

(32) V700 Cloud with 4RE Wifi Conversion equipment

08/07/2023

08/07/2023

NORTHUMBERLAND COUNTY SHERIFF'S DEPARTMENT
195 JUDICIAL PL
HEATHSVILLE, VA 22473

RE: Motorola Quote for (22) V700 Cloud with 4RE Wifi Conversion equipment
Dear Major Allen Garland,

Motorola Solutions is pleased to present NORTHUMBERLAND COUNTY SHERIFF'S DEPARTMENT with this quote for quality communications equipment and services. The development of this quote provided us the opportunity to evaluate your requirements and propose a solution to best fulfill your communications needs.

This information is provided to assist you in your evaluation process. Our goal is to provide NORTHUMBERLAND COUNTY SHERIFF'S DEPARTMENT with the best products and services available in the communications industry. Please direct any questions to John Neese at John.Neese@motorolasolutions.com.

We thank you for the opportunity to provide you with premier communications and look forward to your review and feedback regarding this quote.

Sincerely,

John Neese
Mobile Video ITS (DC, DE, MD, VA)

Billing Address:
 NORTHUMBERLAND COUNTY
 SHERIFF'S DEPARTMENT
 195 JUDICIAL PL
 HEATHSVILLE, VA 22473
 US

Shipping Address:
 NORTHUMBERLAND COUNTY
 SHERIFF'S DEPARTMENT
 195 JUDICIAL PL
 HEATHSVILLE, VA 22473
 US

Quote Date:08/07/2023
 Expiration Date:11/05/2023
 Quote Created By:
 John Neese
 Mobile Video ITS (DC, DE, MD, VA)
 John.Neese@
 motorolasolutions.com
 469-815-9972

End Customer:
 NORTHUMBERLAND COUNTY
 SHERIFF'S DEPARTMENT
 Major Allen Garland
 agarland@northumberlandsheriff.net
 (804) 580-5221

Payment Terms:30 NET

Line #	Item Number	Description	Qty	Term	List Price	Sale Price	Ext. Sale Price
	V700						
1	WGB-0741A	V700 BODY WORN CAMERA FIRSTNET READY	22		\$1,612.50	\$1,290.00	\$28,380.00
2	WGP02798-KIT	V700 MAGNETIC MOUNT WITH BWC BOX	22		Included	Included	Included
3	LSV07S03512A	ESSENTIAL SERVICE WITH ACCIDENTAL DAMAGE AND ADVANCED REPLACEMENT	22	5 YEAR	\$713.00	\$570.40	\$12,548.80
4	SWV07S03593A	SOFTWARE ENHANCEMENTS	22	5 YEAR	Included	Included	Included
5	WGB-0138A	V300 TRANSFER STATION II	2		\$1,868.75	\$1,495.00	\$2,990.00
6	WGP02950	VG700 BATTERY, 3.8V, 4180MAH, REMOVABLE	5		\$137.50	\$110.00	\$550.00
7	WGA00640-KIT1	V300, USB DOCK, D300, DESK CHGR/UPLD KIT	22		\$250.00	\$200.00	\$4,400.00



Line #	Item Number	Description	Qty	Term	List Price	Sale Price	Ext. Sale Price
8	WGA00428-103	CONFIGWIRLESKIT MTIK802.11AC,POE,5GHZ ANT	13 <i>18</i>		\$312.50	\$250.00 <i>+ 1250.⁰⁰</i>	\$3,250.00 <i>4500.⁰⁰</i>
9	WGB-0142A	V300 IN-CAR WIFI BASE BUNDLE FOR 4RE	13 <i>18</i>		\$681.25	\$545.00 <i>+ 2725.⁰⁰</i>	\$7,085.00 <i>9810.⁰⁰</i>
10	WGP01394-001	CBL, WIFI VHCL ANT MNT, NMO, 17'L	13 <i>18</i>		\$75.00	\$60.00 <i>+ 300.⁰⁰</i>	\$780.00 <i>1080.⁰⁰</i>
11	WGP01566-350	ACCESS POINT, MIKROTIK, 802.11AC, 5GHZ	2		\$250.00	\$200.00	\$400.00
12	WGP01567	BRKT KIT POINT UNIVERSAL J-MOUNT	2		\$25.00	\$20.00	\$40.00
13	WGP02494	CABLEASSYBULLETTOAN TENNASMARTPOESWITC H5'	13 <i>18</i>		\$18.75	\$15.00 <i>+ 75.⁰⁰</i>	\$195.00 <i>270.⁰⁰</i>
	V700						
14	WGB-0741A	V700 BODY WORN CAMERA FIRSTNET READY (spares)	2		\$1,612.50	\$1,290.00	\$2,580.00
15	WGP02798-KIT	V700 MAGNETIC MOUNT WITH BWC BOX	2		Included	Included	Included
16	LSV07S03512A	ESSENTIAL SERVICE WITH ACCIDENTAL DAMAGE AND ADVANCED REPLACEMENT	2	5 YEAR	\$713.00	\$570.40	\$1,140.80
17	SWV07S03593A	SOFTWARE ENHANCEMENTS	2	5 YEAR	Included	Included	Included
	VideoManager EL & EX: Video Evidence Management						
18	WGC02001	VIDEOMANAGER EL CLOUD, ANNUAL UNLIMITED STORAGE PER BODY WORN CAMERA*	22	1 YEAR	\$868.75	\$695.00	\$15,290.00



Line #	Item Number	Description	Qty	Term	List Price	Sale Price	Ext. Sale Price
19	WGC02002	VIDEOMANAGER EL CLOUD, ANNUAL UNLIMITED STORAGE PER IN-CAR VIDEO SYSTEM WITH 2 CAMERAS*	13 18	1 YEAR	\$1,118.75	\$895.00	\$11,635.00 16,110
20	WGA00421-501	UPLOAD APPLIANCE, SVR 1U, 60 CONCRNT DEV	1		\$4,812.50	\$3,850.00	\$3,850.00
21	WGW00140-100	EXTENDED WARRANTY, UPLOAD SERVER EL.COM (WGA00421-501), FULL SERVICE ON SITE, 5-YEAR (MONTHS 37-60)	1	5 YEARS	\$812.50	\$650.00	\$650.00
22	WGW00122-400	ON-SITE DEPLOYMENT, TRAINING, CONFIGURATION AND PROJECT MANAGEMENT	1		\$6,250.00	\$5,000.00	\$5,000.00
23	WGW00122-301	MOBILE VIDEO DEPLOYMENT SERVICES	3000		\$1.25	\$1.00	\$3,000.00

Grand Total

\$103,764.60(USD)

\$ 124,224.60

+10% 136,647.06



OPTION # 1

Northumberland County Draft Capital Improvement Program Project Form

(1) Office/Department <u>Northumberland County Sheriff's Office</u>		
(2) Project Title <u>Body Camera / In-Car Camera Bundle Replacement</u>	Project Priority Year Required <u>FY25 (July 1, 2024)</u>	Urgent <input type="checkbox"/> Necessary <input checked="" type="checkbox"/> Desirable <input type="checkbox"/>
(3) Project Description (include sketches, appraisals, plans, etc.) <u>See Attachment #1</u>		
Attachment # <u>1</u>		
(4) Project Justification (includes ramifications if project is not implemented) <u>This project is necessary to replace our outdated and obsolete body cameras and aging in-car cameras. Both cameras work together in function and storing data. Our in-car cameras are aging, but remain available from the vendor. This request is an option for to bring our entire camera systems up to date.</u>		
Attachment #		
(5) Cost (include staffing needs, annual O&M requirements, planning/engineering, equipment/furniture, acquisition, construction) <u>\$331,789.48 (includes a 10% increase for after Jan 1.)</u>		
(6) Funding Source(s)		
Current Revenue <u>X</u>	Grant (Type) _____	
Revenue Bond _____	Loan (Type) _____	
General Obligation Bond _____	Special Assesment _____	
Capital Reserve Fund _____	Other _____	
Requestor <u>Sheriff John A. Beauchamp</u>	Date <u>November 15, 2023</u>	
	Planning Commission Meeting _____	Date/Time _____
Planning Commission Comments: _____ _____ _____ _____ _____ _____		

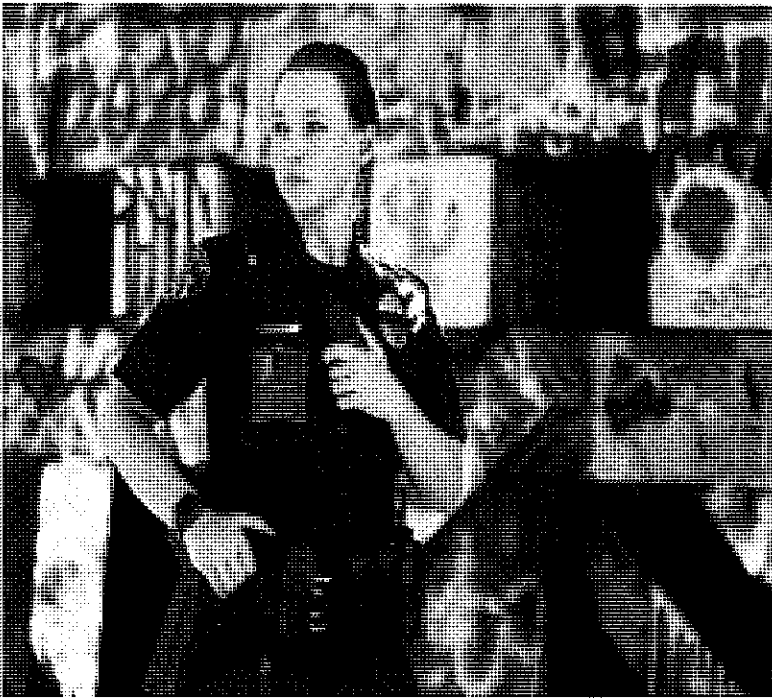

NORTHUMBERLAND COUNTY SHERIFF'S DEPARTMENT

(22) V700 (18) M500 with wifi docks and USB docks

08/07/2023



08/07/2023

NORTHUMBERLAND COUNTY SHERIFF'S DEPARTMENT
195 JUDICIAL PL
HEATHSVILLE, VA 22473

RE: Motorola Quote for (22) V700/ (18) M500 with wifi docks and USB docks
Dear Major Allen Garland,

Motorola Solutions is pleased to present NORTHUMBERLAND COUNTY SHERIFF'S DEPARTMENT with this quote for quality communications equipment and services. The development of this quote provided us the opportunity to evaluate your requirements and propose a solution to best fulfill your communications needs.

This information is provided to assist you in your evaluation process. Our goal is to provide NORTHUMBERLAND COUNTY SHERIFF'S DEPARTMENT with the best products and services available in the communications industry. Please direct any questions to John Neese at John.Neese@motorolasolutions.com.

We thank you for the opportunity to provide you with premier communications and look forward to your review and feedback regarding this quote.

Sincerely,

John Neese
Mobile Video ITS (DC, DE, MD, VA)



QUOTE-2267717
 (22) V700/ (18) M500 with wifi docks
 and USB docks

Billing Address:
 NORTHUMBERLAND COUNTY
 SHERIFF'S DEPARTMENT
 195 JUDICIAL PL
 HEATHSVILLE, VA 22473
 US

Shipping Address:
 NORTHUMBERLAND COUNTY
 SHERIFF'S DEPARTMENT
 195 JUDICIAL PL
 HEATHSVILLE, VA 22473
 US

Quote Date:08/07/2023
Expiration Date:11/05/2023
Quote Created By:
 John Neese
 Mobile Video ITS (DC, DE, MD, VA)
 John.Neese@
 motorolasolutions.com
 469-815-9972

End Customer:
 NORTHUMBERLAND COUNTY
 SHERIFF'S DEPARTMENT
 Major Allen Garland
 agarland@northumberlandsheriff.net
 (804) 580-5221

Payment Terms:30 NET

Line #	Item Number	Description	Qty	Term	Sale Price	Ext. Sale Price	Refresh Duration
Video as a Service							
1	AAS-M5-BWC-5YR	M500 IN-CAR SYSTEM WITH BODY WORN CAMERA AND VIDEO MANAGER EL CLOUD - 5 YEARS VIDEO-AS-A-SERVICE	18	5 YEAR	\$13,500.00	\$243,000.00	
2	WGB-0703A	M500 ICV SYSTEM, V300 WIFI DOCK, SPS	18		Included	Included	
3	WGW00502	M500 EXTENDED WARRANTY	18	5 YEAR	Included	Included	
4	WGP01394-001	CBL, WIFI VHCL ANT MNT, NMO, 17'L	18		Included	Included	
5	WGP02225-202-KIT	BRKT KIT WI-FI BASE UNIVERSAL W/ SCREWS	13		\$25.00	\$325.00	



Any sales transaction following Motorola's quote is based on and subject to the terms and conditions of the valid and executed written contract between Customer and Motorola (the "Underlying Agreement") that authorizes Customer to purchase equipment and/or services or license software (collectively "Products"). If no Underlying Agreement exists between Motorola and Customer, then Motorola's Standard Terms of Use and Motorola's Standard Terms and Conditions of Sales and Supply shall govern the purchase of the Products.
 Motorola Solutions, Inc.: 500 West Monroe, United States - 60661 - #: 36-1115800

Line #	Item Number	Description	Qty	Term	Sale Price	Ext. Sale Price	Refresh Duration
6	WGC02002-VAAS	VIDEOMANAGER EL CLOUD, ANNUAL UNLIMITED STORAGE PER IN-CAR VIDEO SYSTEM WITH 2 CAMERAS VAAS*	18	5 YEAR	Included	Included	
7	WGB-0741A	V700 BODY WORN CAMERA FIRSTNET READY	18		Included	Included	3 YEAR
8	WGP02798-KIT	V700 MAGNETIC MOUNT WITH BWC BOX	18		Included	Included	
9	LSV07S03512A	ESSENTIAL SERVICE WITH ACCIDENTAL DAMAGE AND ADVANCED REPLACEMENT	18	5 YEAR	Included	Included	
10	SWV07S03593A	SOFTWARE ENHANCEMENTS	18	5 YEAR	Included	Included	
11	WGC02001-VAAS	VIDEOMANAGER EL CLOUD, ANNUAL UNLIMITED STORAGE PER BODY WORN CAMERA VAAS*	18	5 YEAR	Included	Included	
12	AAS-BWC-USB-DOC	V300/V700 USB CHARGE/ UPLOAD DOCK - 5 YEARS VIDEO-AS-A-SERVICE (\$4 PER MON)	22	5 YEAR	\$240.00	\$5,280.00	
13	WGB-0178AAS	VIDEO EQUIPMENT, V300/ V700 USB DESKTOP DOCK VAAS (\$4 PER MON)	22		Included	Included	
14	WGB-0138AAS	VIDEO EQUIPMENT, V300/ V700 TRANSFER STATION (\$30 PER MON)	2		Included	Included	
15	WGP02950	V700 BATTERY, 3.8V, 4180MAH, REMOVABLE	5		\$110.00	\$550.00	
16	AAS-BWC-XFS-DOC	V300/V700 TRANSFER STATION - 5 YEARS VIDEO-AS-A-SERVICE (\$30 PER MON)	1	5 YEAR	\$1,800.00	\$1,800.00	



Any sales transaction following Motorola's quote is based on and subject to the terms and conditions of the valid and executed written contract between Customer and Motorola (the "Underlying Agreement") that authorizes Customer to purchase equipment and/or services or license software (collectively "Products"). If no Underlying Agreement exists between Motorola and Customer, then Motorola's Standard Terms of Use and Motorola's Standard Terms and Conditions of Sales and Supply shall govern the purchase of the Products.
 Motorola Solutions, Inc.: 500 West Monroe, United States - 60661 - #: 36-1115800

Line #	Item Number	Description	Qty	Term	Sale Price	Ext. Sale Price	Refresh Duration
17	SSV00S01450B	LEARNER LXP SUBSCRIPTION*	25	5 YEAR	\$0.00	\$0.00	
18	WGP01566-350	ACCESS POINT, MIKROTIK, 802.11AC, 5GHZ	2		\$200.00	\$400.00	
19	WGB-0189A	MTIK CONF KIT,802.11AC,M500POE,5 GHZANT	18		Included	Included	
20	WGP02919-KIT	INSTALL KIT, M500 DVR, CONSOLE MOUNT	18		Included	Included	
21	WGP01567	BRKT KIT POINT UNIVERSAL J-MOUNT	2		\$20.00	\$40.00	
22	PRS-0618A	VAAS MANAGED INSTAL,ONSITE,TRAIN,CO NFIG	1		\$5,000.00	\$5,000.00	
23	WGW00122-301	MOBILE VIDEO DEPLOYMENT SERVICES	2495 1		\$1.00	\$24,951.00	
	Video as a Service						
24	AAS-BWC-5YR-001	BODY WORN CAMERA AND VIDEO MANAGER EL CLOUD - 5 YEARS VIDEO- AS-A-SERVICE	4	5 YEAR	\$4,140.00	\$16,560.00	
25	WGB-0741A	V700 BODY WORN CAMERA FIRSTNET READY	4		Included	Included	3 YEAR
26	WGP02798-KIT	V700 MAGNETIC MOUNT WITH BWC BOX	4		Included	Included	
27	LSV07S03512A	ESSENTIAL SERVICE WITH ACCIDENTAL DAMAGE AND ADVANCED REPLACEMENT	4	5 YEAR	Included	Included	
28	SWV07S03593A	SOFTWARE ENHANCEMENTS	4	5 YEAR	Included	Included	
29	WGC02001-VAAS	VIDEOMANAGER EL CLOUD, ANNUAL UNLIMITED STORAGE PER BODY WORN CAMERA VAAS*	4	5 YEAR	Included	Included	



Any sales transaction following Motorola's quote is based on and subject to the terms and conditions of the valid and executed written contract between Customer and Motorola (the "Underlying Agreement") that authorizes Customer to purchase equipment and/or services or license software (collectively "Products"). If no Underlying Agreement exists between Motorola and Customer, then Motorola's Standard Terms of Use and Motorola's Standard Terms and Conditions of Sales and Supply shall govern the purchase of the Products.

Motorola Solutions, Inc.: 500 West Monroe, United States - 60661 ~ #: 36-1115800

Line #	Item Number	Description	Qty	Term	Sale Price	Ext. Sale Price	Refresh Duration
	V700						
30	WGB-0741A	V700 BODY WORN CAMERA FIRSTNET READY (spares)	2		\$1,290.00	\$2,580.00	
31	WGP02798-KIT	V700 MAGNETIC MOUNT WITH BWC BOX	2		Included	Included	
32	LSV07S03512A	ESSENTIAL SERVICE WITH ACCIDENTAL DAMAGE AND ADVANCED REPLACEMENT	2	5 YEAR	\$570.40	\$1,140.80	
33	SWV07S03593A	SOFTWARE ENHANCEMENTS	2	5 YEAR	Included	Included	

Grand Total
\$301,626.80(USD)
+ 10% 331,789.48
Pricing Summary

	Sale Price	
Upfront Costs for Hardware, Accessories and Implementation (if applicable), plus Subscription Fee	\$87,402.16	\$0.00
Year 2 Subscription Fee	\$53,556.16	\$0.00
Year 3 Subscription Fee	\$53,556.16	\$0.00
Year 4 Subscription Fee	\$53,556.16	\$0.00
Year 5 Subscription Fee	\$53,556.16	\$0.00
Grand Total System Price	\$301,626.80	\$0.00

Notes:

- Additional information is required for one or more items on the quote for an order.
- Unless otherwise noted, this quote excludes sales tax or other applicable taxes (such as Goods and Services Tax, sales tax, Value Added Tax and other taxes of a similar nature). Any tax the customer is subject to will be added to invoices.
- Unless otherwise noted in this quote / order, installation of equipment is not included.



Any sales transaction following Motorola's quote is based on and subject to the terms and conditions of the valid and executed written contract between Customer and Motorola (the "Underlying Agreement") that authorizes Customer to purchase equipment and/or services or license software (collectively "Products"). If no Underlying Agreement exists between Motorola and Customer, then Motorola's Standard Terms of Use and Motorola's Standard Terms and Conditions of Sales and Supply shall govern the purchase of the Products.
 Motorola Solutions, Inc.: 500 West Monroe, United States - 60661 - #: 36-1115800

Northumberland County
Capital Improvement Program
2025-2029

Section 4 School Board

Priority/Rank	Location/Department	Item	Description	Estimated Cost	Funding Source
Urgent	Transportation	Activity Bus	White activity bus for smaller teams that does not require a CDL.	\$88,216.00	
Urgent	Transportation	Bus Camera System	Update camera surveillance on all buses	\$98,749.48	
Urgent	Transportation	School Buses (2)	Purchase of two new 77 passenger buses	\$127,321.00-\$140,832.00 each	
Urgent	Transportation	Vans (2)	Purchase of two mini vans	\$18,000-\$20,000 each	
Urgent/01	Maintenance	NES Boiler Replacement	Replace the existing oil fire boilers w/ propane boiler condensing units	\$174,694.00	
Urgent/02	Maintenance	NMS-NHS Concrete walkway repairs	Replace the existing concrete pavers at each entry point of the NMS/NHS facility with concrete walkways to eliminate existing trip hazards.	\$53,145.00	
Urgent/03	Maintenance	NES-NMS-NHS Well Replacement	Abandon one of the two onsite wells due to improper grouting and replace with a new well. This is a DEQ mandate.	\$450,000	
Urgent/04	Maintenance/IT	NCPS INTEGRATED BUILDING SECURITY/ACCESS	Update the current building security and access systems with one integrated system that requires only one licence. An integrated system will be able to communicate between all systems, allowing each function to aid in the functionality of the other.	\$653,981.38	
Urgent/05	Maintenance	NES Rooftop Stairway Installation	Fabricate a galvanized stairway to provide access to the NES roof equipment.	\$63,756	
Urgent/06	Maintenance	Athletic Track Resurfacing	Remove all existing rubberized surface material on the athletic track, replace with new material and reapply all track markings.	\$292,540	
Urgent/07	Maintenance	NES Flooring Upgrades	Replace remaining VCT flooring at NES with LVT Flooring due to severe wear and tear.	\$492,687.00	
Urgent/08	Maintenance	NES Generator Replacement	Replace existing generator and switchgear with a new 125kw generator set and switchgear	\$46,239.28	
Urgent/09	Maintenance	NES Playground Relocation	Upgrade the existing NES playground surface and all equipment. New surface will prevent water build-up. Provide better security fencing around perimeter.		
Necessary/10	Maintenance	Bus Garage Security Fence	Replace failing security fence around bus shop perimeter.	\$39,925	
Necessary/11	Maintenance	NMS GYM FLOOR RESURFACING	Completely sand NMS gym floor, replace all markings, and rescreen to ensure longevity.	\$17,645.00	
Necessary/12	Maintenance	NCPS Maintenance Service/Plow Truck	Replace existing service truck to wear, tear, and high mileage with a new snow plow capable service truck.	\$49,885.64	
Necessary/13	Maintenance	NMS-NHS RTUJ Replacement	Replace existing Roof Top HVAC units with new, dehumidification ready, Variable Frequency Drive RTU's.		

CUSTOMER: Northumberland School Division
ATTENTION: Stacy Branem
SALESPERSON: Mike Wirt
DATE: 10/17/2023
BID QTY: 1
RFP: E194-90742

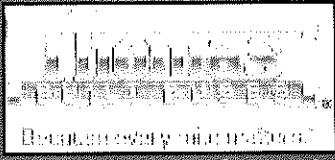

Evington - Chesapeake - Northern VA - Richmond

P.O. Box 495 Rustburg, VA - 491-821-8203 - sonnymerryman.com

PASSENGER CAPACITY		SONNY MERRYMAN INC
BUS TYPE: A16	White Activity 041 14 Passenger	
BASE QTY: 1-10		\$ 79,112
OPTIONS COST		\$ 9,104
TOTAL BID PRICE PER UNIT		\$ 88,216
TOTAL BID PRICE		\$ 88,216

QTY	OPTION TYPE	OPTION DESCRIPTION	SONNY MERRYMAN INC.	\$	9,104
QTY	OPTIONS	OPTION DESCRIPTION	PRICE	EXTENDED PRICE	
1	Audio/Video	AM/FM	\$ -	STD	
1	Cell Phone	Electrical Power Supply - Cell Phone	\$ -	STD	
1	Child Reminder	Child reminder system	\$ -	STD	
1	Doors	Electric Powered Entrance Door Split Leaf, Outward Opening	\$ 689	\$ 689	
1	Doors	Koroseal entrance steps	\$ 116	\$ 116	
1	Doors	Stainless steel assist rails mounted fore and aft of front service door	\$ 83	\$ 83	
1	Doors	Toggle-type main door control switch	\$ -	STD	
1	Driver Seat	Barrier cover with two pouches behind driver seat	\$ 45	\$ 45	
1	Engine	GM Chassis 6.6 L Gas Engine		STD	
1	Engine	Anti-Theft Catalytic Converter Guards		\$ 194	
1	Exterior	Mud Flaps	\$ 43	\$ 43	
1	HVAC	53,000 BTU rear A/C	\$ 4,350	\$ 4,350	
1	HVAC	Dash Air - 15,000 BTU	\$ -	STD	
1	Lights	Driver's LED light w/separate switch 1 light	\$ 31	\$ 31	
1	Lights	LED Dome Lights	\$ 189	\$ 189	
1	Lights	LED Exterior Light Pkg.	\$ 295	\$ 295	
1	Mirrors	Heated and Remote Control	\$ 574	\$ 574	
1	Noise Abatement	Perforated headlining in driver's area	\$ 94	\$ 94	
7	Seats	T3 Bucket Seating	\$ 250	\$ 1,750	
14	Seats	Seat belts, \$ per belt	\$ 31	\$ 434	
1	Steering	Tilt/ ONLY	\$ -	STD	
1	Windows, Glass	Passenger Window - Tinted	\$ 217	\$ 217	

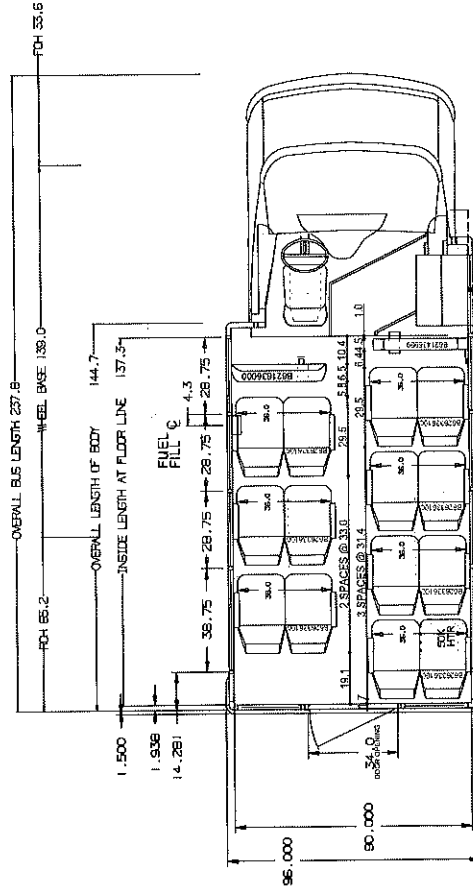
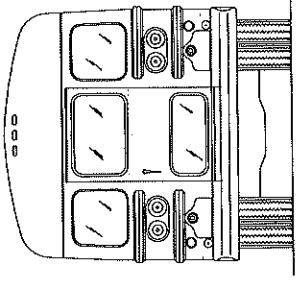
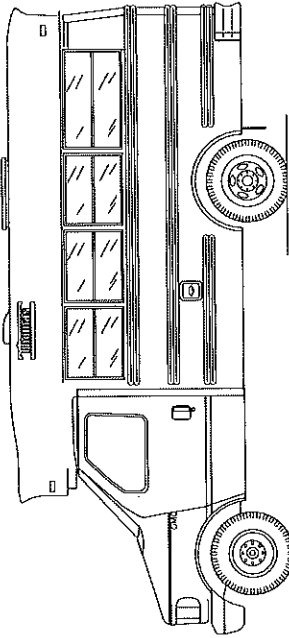

NOTES:
 "WARNING: A/C OPTION EQUIPPED UNIT"

Model: Minotour DRW
 Units Ordered: 3
 Order Numbers: 44296 - 44298
 Quote Number: 139903
 Locality: VA
 Build Date: 9/15/2003

- GENERAL NOTES:
1. FRONT TRIM, SUCH AS CHROME OR ROOF LUGGAGE RACKS, AND OTHER TRIMS ARE SHOWN IN ONE VIEW ONLY FOR REFERENCE.
 2. THIS DRAWING IS A REPRESENTATIVE DRAWING. IT IS NOT TO BE USED AS A BASIS FOR CONSTRUCTION OF A PHYSICAL UNIT.
 3. THE DIMENSIONS ARE NOT TO BE USED FOR CONSTRUCTION OF A PHYSICAL UNIT.
 4. THE DIMENSIONS ARE NOT TO BE USED FOR CONSTRUCTION OF A PHYSICAL UNIT.
 5. THE DIMENSIONS ARE NOT TO BE USED FOR CONSTRUCTION OF A PHYSICAL UNIT.
 6. THE DIMENSIONS ARE NOT TO BE USED FOR CONSTRUCTION OF A PHYSICAL UNIT.
 7. THE DIMENSIONS ARE NOT TO BE USED FOR CONSTRUCTION OF A PHYSICAL UNIT.
 8. THE DIMENSIONS ARE NOT TO BE USED FOR CONSTRUCTION OF A PHYSICAL UNIT.
 9. THE DIMENSIONS ARE NOT TO BE USED FOR CONSTRUCTION OF A PHYSICAL UNIT.
 10. THE DIMENSIONS ARE NOT TO BE USED FOR CONSTRUCTION OF A PHYSICAL UNIT.
 11. THE DIMENSIONS ARE NOT TO BE USED FOR CONSTRUCTION OF A PHYSICAL UNIT.
 12. THE DIMENSIONS ARE NOT TO BE USED FOR CONSTRUCTION OF A PHYSICAL UNIT.
 13. THE DIMENSIONS ARE NOT TO BE USED FOR CONSTRUCTION OF A PHYSICAL UNIT.
 14. THE DIMENSIONS ARE NOT TO BE USED FOR CONSTRUCTION OF A PHYSICAL UNIT.
 15. THE DIMENSIONS ARE NOT TO BE USED FOR CONSTRUCTION OF A PHYSICAL UNIT.
 16. THE DIMENSIONS ARE NOT TO BE USED FOR CONSTRUCTION OF A PHYSICAL UNIT.
 17. THE DIMENSIONS ARE NOT TO BE USED FOR CONSTRUCTION OF A PHYSICAL UNIT.
 18. THE DIMENSIONS ARE NOT TO BE USED FOR CONSTRUCTION OF A PHYSICAL UNIT.
 19. THE DIMENSIONS ARE NOT TO BE USED FOR CONSTRUCTION OF A PHYSICAL UNIT.
 20. THE DIMENSIONS ARE NOT TO BE USED FOR CONSTRUCTION OF A PHYSICAL UNIT.
 21. THE DIMENSIONS ARE NOT TO BE USED FOR CONSTRUCTION OF A PHYSICAL UNIT.
 22. THE DIMENSIONS ARE NOT TO BE USED FOR CONSTRUCTION OF A PHYSICAL UNIT.
 23. THE DIMENSIONS ARE NOT TO BE USED FOR CONSTRUCTION OF A PHYSICAL UNIT.
 24. THE DIMENSIONS ARE NOT TO BE USED FOR CONSTRUCTION OF A PHYSICAL UNIT.
 25. THE DIMENSIONS ARE NOT TO BE USED FOR CONSTRUCTION OF A PHYSICAL UNIT.
 26. THE DIMENSIONS ARE NOT TO BE USED FOR CONSTRUCTION OF A PHYSICAL UNIT.
 27. THE DIMENSIONS ARE NOT TO BE USED FOR CONSTRUCTION OF A PHYSICAL UNIT.
 28. THE DIMENSIONS ARE NOT TO BE USED FOR CONSTRUCTION OF A PHYSICAL UNIT.
 29. THE DIMENSIONS ARE NOT TO BE USED FOR CONSTRUCTION OF A PHYSICAL UNIT.
 30. THE DIMENSIONS ARE NOT TO BE USED FOR CONSTRUCTION OF A PHYSICAL UNIT.
 31. THE DIMENSIONS ARE NOT TO BE USED FOR CONSTRUCTION OF A PHYSICAL UNIT.
 32. THE DIMENSIONS ARE NOT TO BE USED FOR CONSTRUCTION OF A PHYSICAL UNIT.
 33. THE DIMENSIONS ARE NOT TO BE USED FOR CONSTRUCTION OF A PHYSICAL UNIT.
 34. THE DIMENSIONS ARE NOT TO BE USED FOR CONSTRUCTION OF A PHYSICAL UNIT.
 35. THE DIMENSIONS ARE NOT TO BE USED FOR CONSTRUCTION OF A PHYSICAL UNIT.
 36. THE DIMENSIONS ARE NOT TO BE USED FOR CONSTRUCTION OF A PHYSICAL UNIT.
 37. THE DIMENSIONS ARE NOT TO BE USED FOR CONSTRUCTION OF A PHYSICAL UNIT.
 38. THE DIMENSIONS ARE NOT TO BE USED FOR CONSTRUCTION OF A PHYSICAL UNIT.
 39. THE DIMENSIONS ARE NOT TO BE USED FOR CONSTRUCTION OF A PHYSICAL UNIT.
 40. THE DIMENSIONS ARE NOT TO BE USED FOR CONSTRUCTION OF A PHYSICAL UNIT.
 41. THE DIMENSIONS ARE NOT TO BE USED FOR CONSTRUCTION OF A PHYSICAL UNIT.
 42. THE DIMENSIONS ARE NOT TO BE USED FOR CONSTRUCTION OF A PHYSICAL UNIT.
 43. THE DIMENSIONS ARE NOT TO BE USED FOR CONSTRUCTION OF A PHYSICAL UNIT.
 44. THE DIMENSIONS ARE NOT TO BE USED FOR CONSTRUCTION OF A PHYSICAL UNIT.
 45. THE DIMENSIONS ARE NOT TO BE USED FOR CONSTRUCTION OF A PHYSICAL UNIT.
 46. THE DIMENSIONS ARE NOT TO BE USED FOR CONSTRUCTION OF A PHYSICAL UNIT.
 47. THE DIMENSIONS ARE NOT TO BE USED FOR CONSTRUCTION OF A PHYSICAL UNIT.
 48. THE DIMENSIONS ARE NOT TO BE USED FOR CONSTRUCTION OF A PHYSICAL UNIT.
 49. THE DIMENSIONS ARE NOT TO BE USED FOR CONSTRUCTION OF A PHYSICAL UNIT.
 50. THE DIMENSIONS ARE NOT TO BE USED FOR CONSTRUCTION OF A PHYSICAL UNIT.
 51. THE DIMENSIONS ARE NOT TO BE USED FOR CONSTRUCTION OF A PHYSICAL UNIT.
 52. THE DIMENSIONS ARE NOT TO BE USED FOR CONSTRUCTION OF A PHYSICAL UNIT.
 53. THE DIMENSIONS ARE NOT TO BE USED FOR CONSTRUCTION OF A PHYSICAL UNIT.
 54. THE DIMENSIONS ARE NOT TO BE USED FOR CONSTRUCTION OF A PHYSICAL UNIT.
 55. THE DIMENSIONS ARE NOT TO BE USED FOR CONSTRUCTION OF A PHYSICAL UNIT.
 56. THE DIMENSIONS ARE NOT TO BE USED FOR CONSTRUCTION OF A PHYSICAL UNIT.
 57. THE DIMENSIONS ARE NOT TO BE USED FOR CONSTRUCTION OF A PHYSICAL UNIT.
 58. THE DIMENSIONS ARE NOT TO BE USED FOR CONSTRUCTION OF A PHYSICAL UNIT.
 59. THE DIMENSIONS ARE NOT TO BE USED FOR CONSTRUCTION OF A PHYSICAL UNIT.
 60. THE DIMENSIONS ARE NOT TO BE USED FOR CONSTRUCTION OF A PHYSICAL UNIT.
 61. THE DIMENSIONS ARE NOT TO BE USED FOR CONSTRUCTION OF A PHYSICAL UNIT.
 62. THE DIMENSIONS ARE NOT TO BE USED FOR CONSTRUCTION OF A PHYSICAL UNIT.
 63. THE DIMENSIONS ARE NOT TO BE USED FOR CONSTRUCTION OF A PHYSICAL UNIT.
 64. THE DIMENSIONS ARE NOT TO BE USED FOR CONSTRUCTION OF A PHYSICAL UNIT.
 65. THE DIMENSIONS ARE NOT TO BE USED FOR CONSTRUCTION OF A PHYSICAL UNIT.
 66. THE DIMENSIONS ARE NOT TO BE USED FOR CONSTRUCTION OF A PHYSICAL UNIT.
 67. THE DIMENSIONS ARE NOT TO BE USED FOR CONSTRUCTION OF A PHYSICAL UNIT.
 68. THE DIMENSIONS ARE NOT TO BE USED FOR CONSTRUCTION OF A PHYSICAL UNIT.
 69. THE DIMENSIONS ARE NOT TO BE USED FOR CONSTRUCTION OF A PHYSICAL UNIT.
 70. THE DIMENSIONS ARE NOT TO BE USED FOR CONSTRUCTION OF A PHYSICAL UNIT.
 71. THE DIMENSIONS ARE NOT TO BE USED FOR CONSTRUCTION OF A PHYSICAL UNIT.
 72. THE DIMENSIONS ARE NOT TO BE USED FOR CONSTRUCTION OF A PHYSICAL UNIT.
 73. THE DIMENSIONS ARE NOT TO BE USED FOR CONSTRUCTION OF A PHYSICAL UNIT.
 74. THE DIMENSIONS ARE NOT TO BE USED FOR CONSTRUCTION OF A PHYSICAL UNIT.
 75. THE DIMENSIONS ARE NOT TO BE USED FOR CONSTRUCTION OF A PHYSICAL UNIT.
 76. THE DIMENSIONS ARE NOT TO BE USED FOR CONSTRUCTION OF A PHYSICAL UNIT.
 77. THE DIMENSIONS ARE NOT TO BE USED FOR CONSTRUCTION OF A PHYSICAL UNIT.
 78. THE DIMENSIONS ARE NOT TO BE USED FOR CONSTRUCTION OF A PHYSICAL UNIT.
 79. THE DIMENSIONS ARE NOT TO BE USED FOR CONSTRUCTION OF A PHYSICAL UNIT.
 80. THE DIMENSIONS ARE NOT TO BE USED FOR CONSTRUCTION OF A PHYSICAL UNIT.
 81. THE DIMENSIONS ARE NOT TO BE USED FOR CONSTRUCTION OF A PHYSICAL UNIT.
 82. THE DIMENSIONS ARE NOT TO BE USED FOR CONSTRUCTION OF A PHYSICAL UNIT.
 83. THE DIMENSIONS ARE NOT TO BE USED FOR CONSTRUCTION OF A PHYSICAL UNIT.
 84. THE DIMENSIONS ARE NOT TO BE USED FOR CONSTRUCTION OF A PHYSICAL UNIT.
 85. THE DIMENSIONS ARE NOT TO BE USED FOR CONSTRUCTION OF A PHYSICAL UNIT.
 86. THE DIMENSIONS ARE NOT TO BE USED FOR CONSTRUCTION OF A PHYSICAL UNIT.
 87. THE DIMENSIONS ARE NOT TO BE USED FOR CONSTRUCTION OF A PHYSICAL UNIT.
 88. THE DIMENSIONS ARE NOT TO BE USED FOR CONSTRUCTION OF A PHYSICAL UNIT.
 89. THE DIMENSIONS ARE NOT TO BE USED FOR CONSTRUCTION OF A PHYSICAL UNIT.
 90. THE DIMENSIONS ARE NOT TO BE USED FOR CONSTRUCTION OF A PHYSICAL UNIT.
 91. THE DIMENSIONS ARE NOT TO BE USED FOR CONSTRUCTION OF A PHYSICAL UNIT.
 92. THE DIMENSIONS ARE NOT TO BE USED FOR CONSTRUCTION OF A PHYSICAL UNIT.
 93. THE DIMENSIONS ARE NOT TO BE USED FOR CONSTRUCTION OF A PHYSICAL UNIT.
 94. THE DIMENSIONS ARE NOT TO BE USED FOR CONSTRUCTION OF A PHYSICAL UNIT.
 95. THE DIMENSIONS ARE NOT TO BE USED FOR CONSTRUCTION OF A PHYSICAL UNIT.
 96. THE DIMENSIONS ARE NOT TO BE USED FOR CONSTRUCTION OF A PHYSICAL UNIT.
 97. THE DIMENSIONS ARE NOT TO BE USED FOR CONSTRUCTION OF A PHYSICAL UNIT.
 98. THE DIMENSIONS ARE NOT TO BE USED FOR CONSTRUCTION OF A PHYSICAL UNIT.
 99. THE DIMENSIONS ARE NOT TO BE USED FOR CONSTRUCTION OF A PHYSICAL UNIT.
 100. THE DIMENSIONS ARE NOT TO BE USED FOR CONSTRUCTION OF A PHYSICAL UNIT.

THOMAS BUILT BUSES, INC.
 1700 S. BIRCHMOUNT ROAD
 P.O. BOX 100
 JACKSONVILLE, FLORIDA 32231-0100
 TEL: (904) 731-1111
 FAX: (904) 731-1112
 WWW.TBBI.COM

TITLE: PLAN AND ELEVATION
 BODY 041MN
 DWN:10/03 BY:JAW/S/E
 SCALE: 3/8"=12"
 SHEET NO: S
 213382

CAD DRAWING
 DO NOT
 MAKE
 MANUAL
 CHANGES

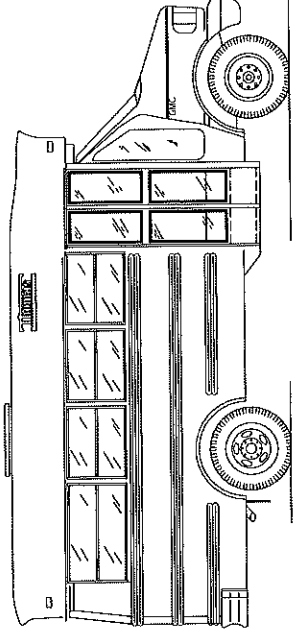



Minotour

From after-school youth groups to senior center outings, a safe, comfortable mode of transportation is non-negotiable. That's why we equipped the compact Minotour with all the peace-of-mind features that come standard in our larger buses, like the one-piece skirt-to-skirt roof bows and the wrap-around bumper. And while safety comes standard in every Minotour, an impressive list of features can be customized to best serve your passengers. Since 1936, Thomas Built has been building safe buses to meet the needs of passengers, drivers and the community. And with one of the most extensive dealer networks in the industry, there's always support nearby when you need it.

SPECIFICATIONS

Passenger capacity

Up to 30

Wheelbase

Ford® Chassis: 138" or 158"

GM® Chassis: 139" or 159"

GVWR

SRW 10,100 lbs., DRW 10,050-14,500 lbs.

Engine

GM gas 4.8L V8, 6.0L V8;

GM diesel 6.6L V8;

Ford gas 5.4L V8, 6.8L V10

Propane option

GM 6.0L LPG, with fully-integrated liquid propane injection system

CNG option

GM 6.0L Vortec powered by IMPCO Automotive



Because every mile matters™

Minotaur

SAFETY

- Meets or exceeds FMVSS/CMVSS
- Built like a full-size school bus
- Safety cage body construction with one-piece skirt-to-skirt roof bows
- Two internal roof crash rails for rollover protection
- Daytime running lights
- Four-wheel anti-lock brakes
- 42" x 47" glass-paneled rear emergency door

DRIVABILITY/COMFORT

- 73" interior headroom
- Interior dome lights
- Driver-friendly ergonomic instrument panel
- 6" x 16" interior rearview mirror with padded edges
- Thermal poly fiber insulation

DRIVER VISIBILITY

- Driver control panel placed overhead
- Manually-operated front entrance door
- 306 square-inch Saf-T-Vue window

SERVICEABILITY

- Electronics mounted in interior service compartment with light
- Main circuit breaker located inside entrance door as master power to body
- Access to lights from inside the bus

OPTIONS

- Wheelchair lift with 44" wide door
- Remote control/heated mirrors
- Driver's step
- Electrically-operated front entrance door
- Dash and rear A/C
- Various seat options available: bench seat without belts, with lap belts, with 3-point belts; latch; integrated child seat; or coach-style seating
- Roof hatch
- Third center LED brake light
- Child reminder system
- Acoustical headlining
- Manual reset electrical circuit breakers
- Reading lights
- Overhead book racks
- Exterior graphics

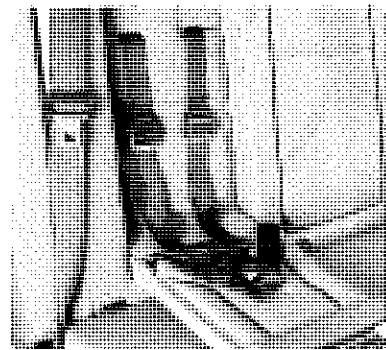

Integrated child seat with seatbelt is one of many seating options.

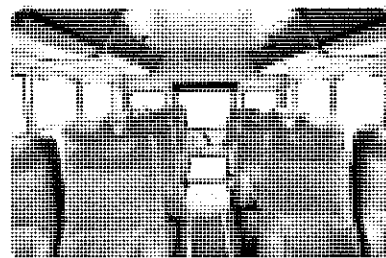

Center aisle with optional book racks and coach-style seating.



The Saf-T-Vue window offers 306 square inches of glass for optimal exterior visibility.

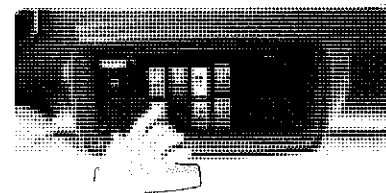

Driver switches located overhead for easy access and enhanced loading visibility.



GATEKEEPER

BILL TO

Company | Northumberland County Public Schools
 Address | 6958 Northumberland Highway
 City | Heathsville
 State / Province | VA
 ZIP / Postal Code | 22473

SHIP TO

Company | Northumberland County Public Schools
 Address | 722 Avalon Ln
 City | Heathsville
 State / Province | VA
 ZIP / Postal Code | 22473

DVR & Camera Placement Sign-Off Required for Installer

Quote Date
October 30, 2023

Doc #:
452244950

Branch:
SB

ORDER INFO

Customer PO | Quote
 Syspro S/C # |
 Delivery Date |
 (Delivery Date to be confirmed by GSI Order Desk - Dates are subject to change)

Sales Rep | Katie/Zach
 Currency | USD CAD

SHIPPING

Shipping Type: Click on Quoted Quoted: \$ 900.00
 Shipping Time: Ground

DVR RECORDERS - WITHOUT CAMERAS

Qty | 28 | G4-Y58 V3 Assembly | 8 Ch DVR | Price Each | 1,073.405 | Total | 30,055.35
 Mobile DVR, includes power cable, sensor cable, key and mounting screws (Y35 & Y62DC no storage; Y35v3/Y58v3 and 508HD4a comes with carrier + ITB HDD; and no cameras)
 G4-Series 4 AHD CH + 4 IP CH HD DVR

COMMON ACCESSORIES

Qty | 28 | G4-TCR-DrvAlert | Tri-Color - Raised Surface Driver Alert Button - Includes Cable | Price Each | 54.518 | Total | 1,526.49
 CAB000371 | Connected Driver Alert Cable | Price Each | 11.314 | Total | 316.78
 Yes | G4-WarningDecal English Only | 1 per Vehicle - English Only Decals | "THIS VEHICLE MAY BE EQUIPPED WITH VIDEO & AUDIO RECORDING DEVICES"
 28 | G4-304 GPS-ANTENNA | GPS - Antenna Only | Price Each | 12.490 | Total | 349.73

CAMERAS (Cameras do not include cables)

Qty | 112 | CAMICAWA11AHD-1.7GREY | HD AHD WIDE ANGLE 720P CAMERA FOR HIGH BACK SEATS | Price Each | 183.200 | Total | 20,518.40
 28 | GSWHC2N-15MLD | 15-foot Camera Cable | 0.000 | 0.00
 56 | GSWHC2N-30MLD | 30-foot Camera Cable | 0.000 | 0.00
 28 | GSWHC2N-60 | 60-foot Camera Cable | 0.000 | 0.00

HD IP CAMERAS (Cameras do not include cables)

Qty | 28 | CAMICAMTW202IP-GREY NO-IR V3 | 28 | 2.8MM | 4.0MM | 8.0MM | Price Each | 321.098 | Total | 8,990.75
 28 | GSWHCAT5-15MLD-B | 15-foot HD IP Camera Cable - Blue | 7.706 | 215.78
 TW202 1080P IP Windshield Camera Grey (No IR)

MISCELLANEOUS & SHIPPING

Qty | 28 | LABOUR | Removal of existing equipment and installation of new Gatekeeper system | Price Each | 850.00 | Total | 23,800.00
 1 | SHIPPING | Shipping price noted above. Freight estimate valid for 30 days - Freight quotes older than 30 days may change without notice | Price Each | 900.00 | Total | 900.00

Product Upgrade Discount
 Tax Rate

Total \$ 86,673.28

GATEKEEPER

BILL TO

Company Northumberland County Public Schools
 Address 6958 Northumberland Highway
 City Heathsville
 State / Province VA
 ZIP / Postal Code 22473

SHIP TO

Company Northumberland County Public Schools
 Address 722 Avalon Ln
 City Heathsville
 State / Province VA
 ZIP / Postal Code 22473

DVR & Camera Placement Sign-Off Required for Installer

Quote Date
 October 30, 2023

Doc #:
 Branch:

452293908
 SB

ORDER INFO

Customer PO Quote
 Syspro S/O #
 Delivery Date
 (Delivery Date to be confirmed by GSI Order Desk - Dates are subject to change)

Sales Rep Katie/Zach
 Currency USD CAD

SHIPPING

Shipping Type: Quoted: \$ 250.00
 Click on Quoted
 Shipping Time: Ground

AI DASH CAMERA

AI-based dash camera is equipped with two built-in cameras and built in WiFi 2.4GHz. 4G/LTE Cellular and can accommodate up to two (2) Micro SD Cards. Two (2) optional/additional cameras (one (1) AHD up to 720p and one (1) IP up to 1080). Additional cameras and storage sold separately.
 AI DASH CAM with built in Driver Status Monitor (DSM) and Advanced Driver Assistance Systems (ADAS) Functions
 AI Dash Camera, flying lead Power Cable (CAB000547), Power box (CAB000545), Windshield installation bracket, Crowbar, Allen wrench and Adhesive on the AI Dash Cam

Qty 10
 Price Each 620.826
 Total 6,208.26

STORAGE (Up to Two (2) Micro SD Cards Per AI Dash Camera)

Qty 10
 Price Each 116.293
 Total 1,162.93

MISCELLANEOUS & SHIPPING

Qty	Part Number	Description	Price Each	Total
10	LABOUR	Installation for AI Dash Cameras	450.00	4,500.00
1	SHIPPING	Shipping price noted above. Freight Estimate valid for 30 days - Freight quotes older than 30 days may change without notice	250.00	250.00

GATEKEEPER SYSTEMS INC.

Abbotsford, BC, V2T 6H1 Tel: 888-666-4833 • Fax: 604-864-8472

- Total excludes PST, GST, HST, local, state, and federal taxes.
- Limited Warranty: 3 years on SD cards & DVRs. 5 years on interior cameras. 1 year on exterior cameras. 1 year on accessories. 1 year on HD & SSD HD
- This quote may or may not contain a cost for shipping. Unless specifically noted otherwise, shipping will be charged.
- Quote is valid for 30 days

Product Upgrade Discount

Tax Rate

Total \$ 12,121.20

This quote may or may not contain a cost for shipping.

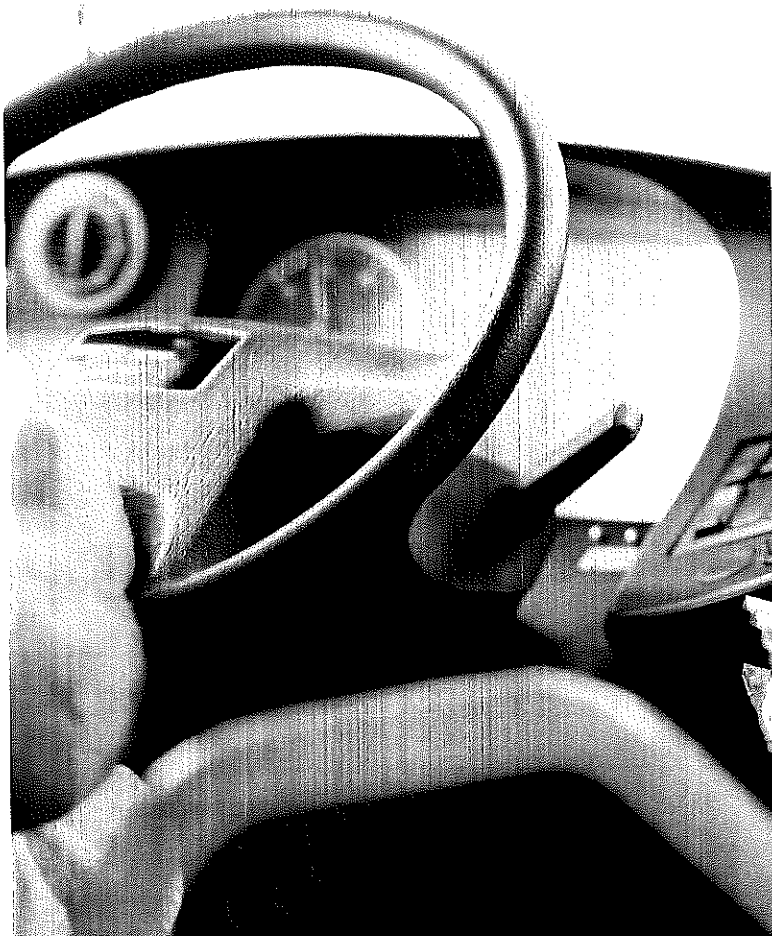

AI DASH CAM WITH BUILT-IN DSM AND ADAS FUNCTIONS

The AI Dash Cam from Gatekeeper is an AI-based dash cam that offers Driver Status Monitor (DSM) and Advanced Driver Assistance Systems (ADAS) functions which detect and alert various driving events and unsafe driving behaviour. The camera supports real-time local driver notifications and is equipped with GPS. When connected to a G4 Enterprise server utilizing either Wi-Fi or cellular, live streaming and previously recorded events are available which enables real-time coaching, remote viewing, event analysis, and long-term storage.

GATEKEEPER

AI DASH CAM

**REAL TIME
NOTIFICATIONS
PROTECTING DRIVERS &
PASSENGERS**



KEY SPECIFICATIONS

- Forward facing camera:
 - Resolution up to 5MP (2560 x 1920) @ 30 FPS
 - Ultra-wide 140° Field of View
 - Advanced Driver Assistance Systems (ADAS) functionality
- Built-in Wi-Fi 2.4 GHz and 4G LTE cellular
- Built-in Wi-Fi GPS and 6-axis inertia sensor
- Driver facing camera:
 - Resolution up to 1080P (1920 x 1080) @ 30 FPS.
 - Ultra-wide 170° Field of View
 - Driver Status Monitor (DSM) functionality
- H.264/H.265 video encoding
- Supports two Micro SD cards
- USA – National Defense Authorization Act (NDAA) compliant

EVENT RECORDING & ANALYSIS IMPROVED DRIVER TRAINING

GATEKEEPER

Gatekeeper Systems Inc.
301-31127 Wheel Avenue
Abbotsford, BC V2T 6H1
Canada

Gatekeeper Systems USA Inc.
200 Rittenhouse Circle Suite 7E
Bristol, PA 19007
USA

The AI Dash Cam is equipped with two built-in cameras. The forward facing camera supports 5MP (2560 x 1920) with ADAS functionality. The driver facing camera supports resolution 1080p (1920 x 1080) with DSM functionality. With two removable Micro SD cards, the AI Dash Cam supports total video storage of up to 1TB.

Videos can be viewed remotely using Gatekeeper's G4 Viewer Plus software. The AI Dash Cam device settings are configurable wirelessly using G4 Connect software application available for Android and iOS mobile devices.

SPECIFICATION

VIDEO RECORDING	Up to 4 channels (Internal: 2 channels; External: 2 additional channels)
CAMERA RESOLUTION	Built-in Cameras: Forward facing camera: 5MP (2560 x 1920) @ 30 FPS Driver facing camera: 1080P (1920 x 1080) @ 30 FPS 2 additional camera channels (optional): 1 x AHD camera up to 1080P @ 20 FPS 1 x IP camera up to 720P @ 20 FPS
IMAGE SETTING	Adjustable Brightness, Chroma, Contrast, Color Saturation, Sharpness
VIDEO CODING	H.265 / H.264
VIDEO BIT RATE	500 Kbps - 8 Mbps
AUDIO COMPRESSION	ADPCM, G.711, G.726. Default: ADPCM
BUILT IN SPEAKER	Included, adjustable volume
STORAGE	
MICRO SD CARD	32GB / 64GB / 128GB / 256GB / 512 GB

FORWARD FACING CAMERA SPECIFICATIONS

SENSOR	1/2.7" 5M pixel CMOS Sensor
ELECTRONIC SHUTTER	1/30 Second - 1/100000 Second
LENS	Focal length: 2.8mm
S/N	≥48db
LENS MOUNT	Built-in lens
WIDE DYNAMIC RANGE (WDR)	Digital WDR
BACKLIGHT COMPENSATION	Supported

DRIVER FACING CAMERA SPECIFICATIONS

SENSOR	1/2.7" 5M pixel CMOS Sensor
ELECTRONIC SHUTTER	1/30 Second - 1/100000 Second
LENS	Focal length: 2.2mm
S/N	≥45db
LENS MOUNT	Built-in lens
WIDE DYNAMIC RANGE (WDR)	Digital WDR
BACKLIGHT COMPENSATION	Supported
INFRARED LAMP	Supported

NETWORK

WIFI	802.11 a/b/g/n 2.4GHz
CELLULAR	4G LTE

GPS

Built-In

SENSOR

6-axis Sensor & Environmental Light Sensor supported

PORTS

RS232	1 channel input
I/O PORT	4 channel input
AV OUT	1 channel
USB	1 mini-USB port

POWER

POWER	12V and 24V nominal
NORMAL POWER CONSUMPTION	7.56W
PEAK POWER CONSUMPTION	12.66W

PHYSICAL

DIMENSIONS (L X W X H)	4.45" x 2.67" x 3.47" (113 mm x 67.8 mm x 88.2 mm)
------------------------	--

WEIGHT	295g
--------	------

ENVIRONMENTAL

OPERATING TEMPERATURE	-40°C - +70°C (-40°F ~ +158°F)
HUMIDITY	15-95% non-condensing

ADAS FUNCTIONS



LDW
LANE DEPARTURE WARNING



HMW
HEADWAY MONITORING WARNING



FCW
FORWARD COLLISION WARNING

DSM FUNCTIONS



LENS COVERED



HANDHELD DEVICE



SEAT BELT UNFASTENED



SMOKING



DISTRACTION



YAWNING

DIMENSION DRAWINGS (UNIT: MM)

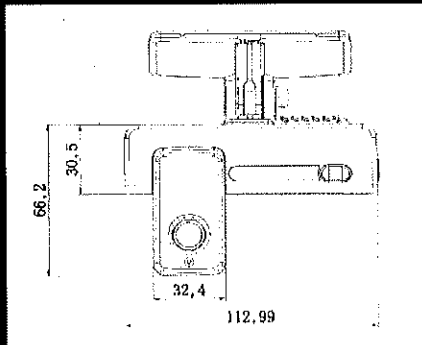

FRONT VIEW

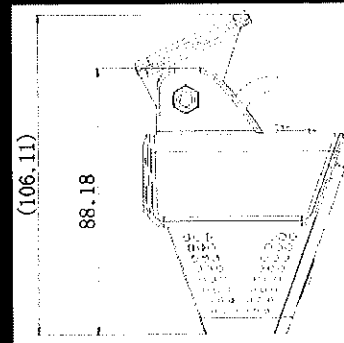

LEFT VIEW

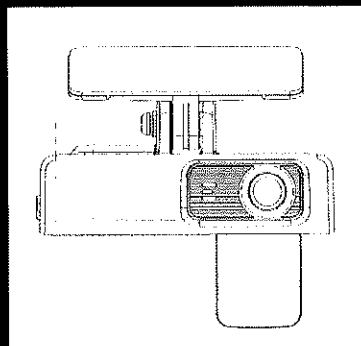

REAR VIEW

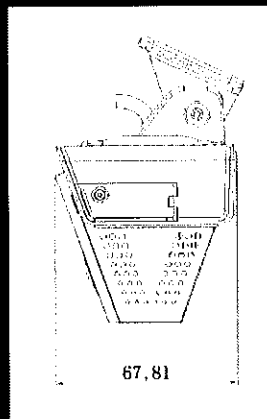

RIGHT VIEW





October 25, 2023
Contract # 005752

Sales Proposal For:

Northumberland County Public Schools

Presented By:

Kangaroo Supply, Inc.

INTEGRATED CE 5 BUS

School Transportation, 77 Passenger PB110

Cummins B6.7, 220 HP, Diesel Engine, Allison 2500 PTS 6-speed Automatic Transmission

- AIR CONDITIONING 120 BTU
- TOW HOOK, FRONT & REAR
- CROSSING GATE, ELECTRIC
- FRONT AXLE MERITOR 10,000 lbs
- BENDIX ANTILOCK BRAKE SYSTEM
- AIR DRYER BENDIX AD-9SI WITH HEATER
- PARKING BRAKE MANUAL PUSH/PULL
- TILT STEERING
- ENGINE EXHAUST BRAKE
- ALTERNATOR LEECE-NEVILLE BRUSHLESS, 12 VOLT, 210 AMP
- BATTERY SYSTEM, FLEETRITE MAINTENANCE-FREE 3 12-VOLT 1980 CCA
- RADIO AM/FM/USB/AUXILIARY, ANTENNA & PA
- HEADLIGHTS ON AUTOMATICALLY WITH WIPERS
- STARTING MOTOR DELCO REMY 38MT
- GRILLE MOLDED IN BLACK
- ENGINE BLOCK HEATER
- SYNTHETIC TRANSMISSION OIL
- HEATER SHUT OFF VALVES (2) BALL VALVE TYPE
- WHEELS FRONT & REAR ACCURIDE 2-HAND HOLE
- SKIRTS 20"
- COMPARTMENT DR STORAGE SIZED FOR 3-RING BINDER INCL. USB-A & USB-C PORT
- TOOL BOX EXTERIOR WITH LOCK
- KEY ALIKE 545 ALL EXTERIOR LOCKS AND DRIVER COMPARTMENT LOCK
- MONITOR POST TRIP INSPECTION LEAVE NO STUDENT BEHIND
- ENTRANCE DOOR ELECTRIC WITH SINGLE PANE GLASS
- STEPWELL HEATER
- SEAT DRIVER AIR SUSPENSION NATIONAL 2000
- STOP ARM FRONT ELECTRIC STROBING LED
- LIGHTS, DRIVER DOME LED
- COMPARTMENT ABOVE DRIVER WITH PADDING
- LIGHTS DOME LED
- LIGHTS EXTERIOR LED
- TIRES 11R22.5 ALL POSITION
- GATEKEEPER 5 CAMERA SYSTEM

Total Quoted Price: \$127,321.00

****Price is not guaranteed until receipt of purchase agreement. All pricing is subject to any and all applicable surcharges at time of build.**

CUSTOMER: Northumberland School Division
 ATTENTION: Stacy Branem
 SALESPERSON: Mike Wirt
 DATE: 10/25/2023
 BID QTY: 1
 RFP: E194-90742

SONNY MERRYMAN INC.
 707 S.W. 49th Rd, Tallahassee, FL 32310-2170
 www.sonnymerryman.com

PASSENGER CAPACITY		SONNY MERRYMAN INC.
BUS TYPE: C77	77 Passenger	
BASE QTY: 1-10		\$ 120,099
	OPTIONS COST	\$ 20,733
	TOTAL BID PRICE PER UNIT	\$ 140,832
	TOTAL BID PRICE	\$ 140,832

QTY	OPTION TYPE	OPTION DESCRIPTION	SONNY MERRYMAN INC. PRICE	EXTENDED PRICE
				\$ 20,733
1	Alternator	200 amp Delco	\$ -	STD
1	Audio/Video	AM/FM/PA	\$ 722	\$ 722
1	Audio/Video	PA - External Speaker	\$ 112	\$ 112
1	Audio/Video	Gatekeeper DVR System	\$ -	\$ 4,095
1	Battery	Battery Disconnect	\$ -	STD
1	Brakes	WABCO SmartTrac Elect Stab Control Incl Traction Control Enhancement	\$ -	STD
1	Cell Phone	Electrical Power Supply - Cell Phone	\$ -	STD
1	Child Reminder	Child reminder system	\$ -	STD
1	Doors	"Vandallock System" locking system	\$ 118	\$ 118
1	Doors	Electric Powered Entrance Door Split Leaf, Outward Opening	\$ -	STD
1	Doors	Stainless steel assist rails mounted fore and aft of front service door	\$ 83	\$ 83
1	Driver Seat	Air ride suspension pedestal	\$ 293	\$ 293
1	Driver Seat	Arm rest (each)	\$ 31	\$ 31
1	Driver Seat	Barrier cover with two pouches behind driver seat	\$ 45	\$ 45
1	Engine	Cummins Diesel Engine Exhaust Brake	\$ 94	\$ 94
1	Engine	Cummins Diesel Engine 220 hp	\$ 1,015	\$ 1,015
1	Engine	Fuel Water Separator (Heated)	\$ -	STD
1	Exterior	Mud Flaps	\$ 43	\$ 43
1	Exterior	Removable winter front grill cover	\$ 48	\$ 48
1	Floor	Plywood Sub Floor	\$ -	STD
1	Fuel Tank	65 gallon	\$ -	STD
1	HVAC	126,000 BTU front & rear A/C	\$ 9,975	\$ 9,975
1	Keys	Ignition Keyed Alike	\$ -	STD
1	Lights	Driver's LED light w/separate switch 1 light	\$ 31	\$ 31
1	Lights	LED Dome Lights	\$ 160	\$ 160
1	Lights	LED Exterior Light Pkg.	\$ 417	\$ 417
1	Lights	LED Headlights	\$ 834	\$ 834
1	Lights	LED Strobe Warning Lights	\$ 1,224	\$ 1,224
1	Locks	A locking device for the driver's window	\$ -	STD
1	Paint	Painted white roof	\$ 512	\$ 512
1	Steering	Tilt/Telescopic	\$ 348	\$ 348
1	Stop Arm	Strobe - LED stop sign	\$ 106	\$ 106
1	Tires	11R22.5 14 Ply	\$ -	STD
1	Tires	Oil lubed front wheel bearings	\$ -	STD
1	Transmission	Allison PTS 2500 (std w/Air Brakes) - 7 Year Warranty	\$ -	STD
1	Windows, Glass	Passenger Window - tinted	\$ 427	\$ 427



This vehicle has passed inspection by an ASE-certified technician.

enterpr



39 Photos



[Summary](#) [Features](#) [Price](#) [Payments](#) [Warranty](#) [Dealer](#) [Review](#)

Used

2020 Dodge Grand Caravan

GT Fleet 4dr Minivan (3.6L 6cyl 6A)

Vehicle Summary

Highlights

Mileage	85,459
Ext. Color	White Knuckle Clear Coat
Int. Color	Black Leather
Engine	Gas
Transmission	Automatic
Drivetrain	Front Wheel Drive
MPG	17/25 City/Hwy MPG ⓘ 20 Combined MPG
Horsepower	283 hp
Max Towing Capacity	3,600 lbs
Seats	7 ⓘ
VIN	2C4RDGEG0LR189026
Stock #	7TMSS9

Vehicle History Report by  **AutoCheck**
A part of Edmunds



0 Accidents

1 Owner



Rental Vehicle

Clean Title

[Buy AutoCheck Full History Report](#)

[Visit NHTSA for recall information](#)

Features

Features that are installed on this 2020 Dodge Grand Caravan GT Fleet.

Black leather trimmed bucket seats ParkView Back-Up Camera

Uconnect w/Bluetooth Wireless Phone

FOB Controls -inc: Cargo Access and R

2nd Row Stow 'N Go Bucket Seats [± more](#)

Comfort & Convenience

Entertainment

Safety

Engine & Exterior

[See all features](#)

Price

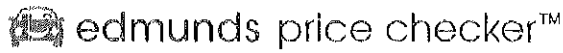

Are you getting a good price? Check it before you buy

Stock#: 7TMSS9

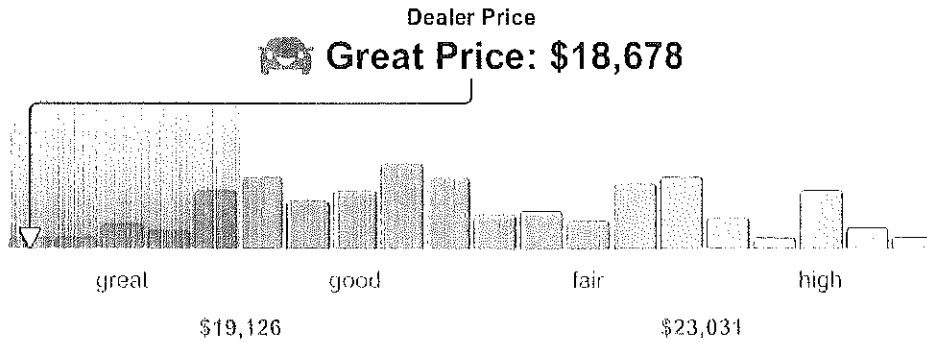

\$18,678

Edmunds considers this used vehicle a **Great Price** because the price is **\$4,081 below market**. 15% of the used inventory currently listed on Edmunds is a great price. Our ratings are accurate and up-to-date – we've analyzed thousands of similar transactions and listings to rate these deals.

Use this form to get the dealer's price quote.

First Name	Last Name
Email	Phone

This information will not be shared with any dealer other than those you select. [Our collection and use of your personal information](#)

Northumberland County Draft Capital Improvement Program Project Form

<p>(1) Office/Department: NCPs Maintenance Department</p>	
<p>(2) Project Title Urgent Necessary Desirable</p> <p style="text-align: center;">Project Priority : URGENT Year Required: 2023</p>	
<p>(3) Project Description (include sketches, appraisals, plans, etc.) Replacement of the two existing 28 year old oil fired boilers with two 999,000 BTU propane boilers.</p> <p>Attachment #</p>	
<p>(4) Project Justification (includes ramifications if project is not implemented) The current oil fired boilers are 28 years old and have surpassed their designed service life. Currently, only one boiler is fully functional and requires constant monitoring to maintain proper operation. Replacing each boiler with two propane boiler systems will provide a cleaner, more efficient means of heat as well as allowing for the discontinued use of an aging underground diesel fuel tank and failing smoke stack.</p> <p>Attachment # L23-0371.pdf</p>	
<p>(5) Cost (include staffing needs, annual O&M requirements, planning/engineering, equipment/furniture, acquisition, construction) \$174,694.</p>	
<p>(6) Funding Source(s)</p> <p>Current Revenue Grant (Type) Revenue Bond Loan (Type) General Obligation Bond Special Assessment Capital Reserve Fund Other</p>	

Requestor Date

Planning Commission Meeting

Date/Time

Planning Commission Comments:

E. McLauchlan & Sons



E. McLauchlan & Sons, Inc.

PO Box 18430 Richmond VA 23226

Phone (804) 648-0492

www.theboilerpeople.com

December 1, 2023

Northumberland County Public Schools
6958 Northumberland Highway, Heathsville, VA 22435

Re: 757 Academic Lane, Heathsville, VA 22437-3316
2 x Lochinvar Knight XL Condensing Boilers

Dear Mr. Jeff Bran:

We will furnish all labor and materials necessary to replace 2 x Bryan Flextube Boilers:

Scope of Work:

- Remove Existing Boilers
- Install 2 x Lochinvar Knight XL Condensing Boilers
Model # KBX 1000N-M13-1012
 - 2 x Lochinvar Natural Gas to LP Conversion Kits
 - 2 x Lochinvar Condensate Kits
 - 2 x Lochinvar VFD Boiler Pump/ 115VAC-1HP/Pump20078K
 - Stack breaching
 - Piping

Phase 1-

- Isolate and drain boiler 2.
- Remove boiler 2.
- Dispose of Boiler 2.
- Prep area for new boiler.
- Set new Lochinvar Boiler.
- Make supply piping connections as needed.
- Make return piping connections as needed.
- Install temporary venting into the existing flu.
- Wire new boiler.
- Perform start up.
- Bring boiler online to the existing system.
- Check proper function.



E. McLauchlan & Sons, Inc.

PO Box 18430 Richmond VA 23226

Phone (804) 648-0492 theboilerpeople.com

Phase 2:

- Isolate boiler #1
- Drain boiler 1
- Remove boiler #1.
- Dispose of boiler #1
- Prepare area for new Lochinvar Boiler.
- Set new boiler in same location as boiler #1
- Pipe and install Primary and Secondary loop.
- Make supply piping connections.
- Make return piping connections.
- Install new CPVC flue. (Both Boilers)
- Wire new boiler system as needed.
- Install new pump
- Insulate new piping
- Install outdoor temperature sensor

Please note that the limits of demolition and the scope of new work will be limited to what is necessary to complete the above. Repair of any piping system deficiencies, mechanical system deficiencies, electrical system deficiencies, and/or control system deficiencies, not specifically listed above, are not included in this scope of work.

All work will be done in accordance with the Virginia Department of Labor & Industry, Boiler and Pressure Vessel Rules & Regulations and the National Board Inspection Code (NBIC).

We hold a current and valid National Board “R” Stamp for shop and field repair of boilers and pressure vessels. The “R” Stamp certificate is issued by the National Board of Boiler & Pressure Vessel Inspectors Association in accordance with the National Board Inspection Code (NBIC). Our certification number is 1875.

All work will be done in accordance with state and local plumbing and mechanical codes.

All materials of construction, provided by us, are to be new and will be equal to or exceed the latest generally accepted industry standards of quality. All work to be performed by us will be done in a neat and workmanlike manner using the latest generally accepted industry standards of practice.

We estimate the time of completion to be approximately (3) Three Weeks to replace both boilers



E. McLauchlan & Sons, Inc.

PO Box 18430 Richmond VA 23226

Phone (804) 648-0492 theboilerpeople.com

All work will be done during our normal working hours of Monday through Friday, 7:00 a.m. to 3:30 p.m. excluding holidays, or on our alternate schedule of Monday through Thursday, 7:00 a.m. to 5:30 p.m. excluding holidays. If weekend work is needed there will be an additional \$3,750.00 per day added.

Your investment \$ 173,121.48

Price includes material/ labor/accommodations/travel to and from Northumberland

This quotation will remain in effect for a period of thirty (30) days from the date of this letter.

We thank you for the opportunity of quoting and await your early reply.

Sincerely,
Paul Cooper

I have read the attached *General Conditions to Contract*, understand them, and accept them as part of this proposal.

I accept this proposal and hereby give notice to proceed with the above scope of work.

Signed

Date

Company

P. O. Number



E. McLauchlan & Sons, Inc.

PO Box 18430 Richmond VA 23226 Phone (804) 648-0492 theboilerpeople.com

GENERAL CONDITIONS TO CONTRACT

Payment: Invoices are payable net within 30 calendar days of billing date. Sales tax will be added when applicable. Customers that are tax exempt must send a state tax exemption form to our office. MasterCard and Visa credit card payments are accepted, net within 8 days of billing date. We reserve the right to request reasonable partial payments as the job progresses. Payments not received within the aforementioned time frame will be subject to a 10% monthly late payment fee. In the event we must commence proceedings to collect any amounts past due, the Customer will be responsible for all interest and our costs for such proceedings, including attorney fees. Projects over \$10,000.00 require 50% paid at the time of PO and 50% upon completion.

Quantity: The price quoted only covers those items as specified in the proposed contract.

Quality: Work performed will be considered satisfactory unless we are notified in writing. Our workmanship is warranted for a year from installation. Materials and equipment are subject to warranties offered by their respective manufacturers.

Termination: If a contract is cancelled, the project scope of work will be handled as a “time and material” job and all time expended and materials purchased, prior to cancellation of the contract, will be billed to the Customer at our prevailing published rates.

Insurance: We carry ample insurance and will provide you with a Certificate upon request.

Changes: Additional work or changes beyond the scope of the contract will be billed at our published rates and must be authorized in writing, prior to the start of work.

Acceptance: Prices quoted are subject to change if not accepted within 30 days. If purchase order numbers are required, they must be issued and recorded on the signed contract.

Limitations: Unless otherwise specified, we do not include in our price provisions for:

- a) Correction for missing or ill-fitting parts provided by others.
- b) Delay time waiting for delivery of materials or equipment not provided by us.
- c) Delay time waiting for facility or area to become available for our work to commence.
- d) Any other delays beyond our control.



E. McLauchlan & Sons, Inc.

PO Box 18430 Richmond VA 23226

Phone (804) 648-0492 theboilerpeople.com

We cannot be liable for repairs done by others following work done by us unless we have been given notice of the defect and unless we have been allowed a reasonable opportunity to inspect and repair the defect.



Standard Features

- › **97% Thermal Efficiency**
- › **Modulating Burner with 10:1 Turndown**
 - Direct Spark Ignition
 - Low NOx Operation
 - Sealed Combustion
 - Low Gas Pressure Operation
- › **Stainless Steel Water Tube Heat Exchanger**
 - ASME-Certified, "H" Stamped
 - 160 psi Working Pressure
 - 50 psi Relief Valve
 - Combustion Analyzer Test Port
 - Fully Welded Design
- › **Smart System Control**
- › **Vertical and Horizontal Direct Vent**
 - Direct Vent up to 150 feet
 - PVC, CPVC, Polypropylene or AL29-4C
 - Factory Supplied Sidewall Vent Termination
- › **Other Features**
 - On/Off Switch
 - Adjustable High Limit with Manual Reset
 - Automatic Reset High Limit
 - Flow Switch
 - Flue Temperature Sensor
 - Low Air Pressure Switch
 - Temperature and Pressure Gauge
 - Condensate Trap
 - 10-Year Limited Warranty (See Warranty)

Smart System Features

- › **CON-X-US Remote Connect**
- › **Smart Touch Touchscreen Operating Control**
- › **Full Color 7" Touchscreen LCD Display**
- › **Loch-N-Link® USB Thumb Drive Port for Easy Programming**
- › **Cascading Sequencer with Built-in Redundancy**
 - Selectable Cascade Type:
 - Lead Lag or Efficiency Optimization
 - Multiple Size Boilers
 - Front-End Loading
- › **3 Reset Temperatures Inputs w/Independent Outdoor Reset Curves for Each**
 - Outdoor Sensor
- › **Four-Pump Control**
 - System Pump with Parameter for Continuous Operation
 - Boiler Pump with Variable-Speed Control
 - Domestic Hot Water Boiler Pump
 - Domestic Hot Water Recirculation Pump Control with Sensor
- › **Building Management System Integration**
 - 0-10 VDC Input to Control Modulation or Setpoint
 - 0-10 VDC Input from Variable-Speed System Pump
 - 0-10 VDC Modulation Rate Output Signal
 - 0-10 VDC Enable/Disable Signal
- › **Programmable System Efficiency Optimizers**
 - Space Heating Night Setback
 - DHW Night Setback
 - Anti-Cycling
 - Ramp Delay
 - Boost Time and Temperature
- › **High-Voltage Terminal Strip**
 - 120 VAC/60 Hertz/1 Phase
 - Pump Contacts for 3 Pumps
- › **Low-Voltage Terminal Strip**
 - Building Recirculation Pump Start/Stop
 - Proving Switch Contacts
 - Alarm Contacts
 - Runtime Contacts
 - 3 Space Heat Thermostat Contacts
 - Tank Thermostat Contacts
 - System Sensor Contacts
 - Tank Sensor Contacts
 - Cascade Contacts
 - 0-10 VDC BMS Contacts
 - 0-10 VDC Boiler Rate Output Contacts
 - 0-10 VDC Boiler Pump Speed Contacts
 - 0-10 VDC System Pump Speed Contacts
 - ModBus/BACnet Contacts
- › **Time Clock**
- › **Data Logging**
 - Ignition Attempts
 - Last 10 Lockouts
 - Space Heat Run Hours
 - Domestic Hot Water Run Hours
 - Custom Maintenance Reminder w/ Contact Info
 - Password Security
 - Customizable Freeze Protection Parameters

Optional Equipment

- Wireless Outdoor Temperature Sensor
- Variable-Speed Boiler Circulator
- Constant-Speed Boiler Circulator
- ModBus Communication
- BMS Gateway to BACnet or LonWorks
- BACnet MSTP
- Alarm on Any Failure
- Condensate Neutralization Kit
- Concentric Vent Kit (KBX0400-KBX650)
- Common Vent Kit
- High and Low Gas Pressure Switches w/Manual Reset (KBX0500-KBX1000)
- Low Water Cut-Off w/Manual Reset & Test

Firing Codes

- M7 California Code
- M9 Standard Construction
- M13 CSD1/FM/GE Gap (KBX0500-KBX1000)

Venting Options

- Direct Vent Vertical
- Direct Vent Horizontal
- Vertical Vent with Sidewall Air Intake
- Sidewall Vent with Rooftop Air Intake
- Vertical Vent with Optional Room Air
- Sidewall Vent with Optional Room Air

NORTHUMBERLAND COUNTY PUBLIC SCHOOLS



NES



NMS

NHS

January 2, 2023
Emergency Procurement Request
Replace Boilers at Northumberland Elementary School
Northumberland County Public Schools

In accordance with Va. Code Sec. 2.2-4303(F), Northumberland County Public Schools issues an Emergency Procurement for the replacement of two boilers at Northumberland Elementary School.

Rationale for Emergency Procurement:

Currently, only one of the two existing boilers is functional. The damage to the outer shell of the non-operating boiler is beyond repair.

The remaining functional boiler is running continuously to achieve the same results that a dual setup provided. The continuous operation has resulted in an excessive consumption for diesel fuel, requiring the Maintenance Department to provide continuous monitoring of the school's fuel levels.

In addition, the remaining functional boiler has been used throughout the milder winter months and has proven to barely meet the requirements of the climate control needs at the elementary school. During the January and February timeframe, when the average daily temperatures will be drastically lower, the remaining functional boiler will not be able to meet the building's requirements for adequate heating.

Further, the increased heating requirements will add increased wear to this boiler, leading to a probable breakdown that will cause heat loss during instructional time. If this sole boiler fails to a point which is comparable to the damage that the non-functioning boiler has experienced, there will be no heat in the elementary school indefinitely.

There is no minimum timeframe for vendor bid submission. A Purchase Order (including all NCPS standard terms and conditions) will be created by Northumberland County Public Schools and will be included in all supporting documentation.

The work to be completed under this Procurement will consist of the demolition and removal of the non-operational boiler, the installation of a new propane condensing unit, all proper electrical wiring and propane supply installation, and the proper tying in of communication with our BACNET Building Controls.

NORTHUMBERLAND COUNTY PUBLIC SCHOOLS



NES



NMS

NHS

Due to the need to keep the existing operational boiler online for adequate climate control, the new boiler will require a temporary connection point into the existing exhaust. Once warmer weather arrives, the remaining oil fired boiler will be taken out of service and a second propane condensing unit will be installed.

At this time the existing building exhaust system will be removed and a new CPVC exhaust piping system will be installed. The installation of just one of these two Propane condensing units will ensure there is an adequate backup for heat supply in the event the remaining Oil Fired Boiler suffers a failure.

A quote has been provided by NWP Energy, the company supplying the school's propane, to install two additional tanks and a larger underground supply piping to the building's propane regulator. The total cost for this installation is \$13,776.03, and it is imperative to include this as part of the emergency procurement process. Once authorization is obtained to proceed the Purchase Order and all other supporting documentation will be submitted to the assigned EVA representative for posting on their website.

Jeffrey D. Brann
Director, Operations and Maintenance



Holly Wargo <hwargo@nucps.net>

[NCPS] Emergency Procurement of NES Boilers

1 message

Jeffrey Brann <jbrann@nucps.net>

Mon, Jan 8, 2024 at 2:05 PM

To: Holly Wargo <hwargo@nucps.net>, Lee Ambrose <lambrose@nucps.net>, Mike Wallace <mwallace@nucps.net>, Martha Williams <mwilliams@nucps.net>

Hi Dr. Wargo,

After much review of the four vendors who have supplied quotes for the NES Boiler project I have determined that the two attached quotes are the only vendors who meet the prerequisites of our emergency procurement. I have submitted invitations to bid to each of these vendors and have gotten verbal approval from both in regards to their willingness to take on this job. Although each quote meets our requirements the quote provided by Mr. Paul Cooper of E. Mclauchlan & Sons best meets our needs. Not only is it the lower bid, Mr. Cooper has detailed the process of keeping the one running boiler online while removing and replacing the damaged unit. By doing this we will be able to keep adequate climate control throughout the building until milder temperatures permit the replacement of the second boiler. Mr. Cooper has given a detailed scope of work for transitioning from the old smoke stack system to the new CPVC exhaust system. Also, with your permission I would like to proceed with the propane system upgrades to ensure no delays are incurred. I am available at any time to discuss.

v/r,

 [Northumberland Elementary Boiler Replacement.pdf](#)

 [Northumberland E.S. - Replace Boilers Proposal ...](#)

Jeffrey D. Brann

Director of Facilities/Maintenance

804-580-0754



Capitol Boiler Works

Modular Efficiency and Reliability

A Service Logic Company

7177 Woodmill Court, Springfield, VA 22151
Phone: 1 (800) 296-6821
www.capitolboilerworks.com

November 2, 2023

Service Job Proposal #L23-0371

Northumberland Co. Schools
PO Box 730
Heathsville, Va. 22473

Northumberland Elementary School
757 Academic Lane
Heathsville, Va. 22473

Attn: Jeff Brann
Phone: (804) 580-0754
Email: jbrann@nucps.net

Page 1 of 2

RE: New Lochinvar KBX1000 heating boilers to replace existing Bryant heating boilers. Each boiler is rated at 999,000 BTU Input / 969,000 BTU Output each. 10:1 Turndown from high to low fire.

Proposal-Acceptance

We hereby submit the scope of work requested with estimates for supplying the necessary labor and material to complete the following:

- 1) Valve off heating loop system from existing boilers. Disconnect boiler system piping, oil piping, exhaust vent, drains, electrical, and drains.
- 2) Existing exhaust flue will be removed back to vertical penetration thru the roof.
- 3) Provide all necessary labor and rigging to remove existing Bryan hot water boilers from site.
- 4) Provide all necessary labor to set new Lochinvar boilers on existing housekeeping pad.
- 5) Supply and install all necessary pipe, valves, and fittings to connect existing heating supply and return piping together to create a secondary heating loop. New low loss tees and valves will be added for boiler primary loop piping to connect.
- 6) Supply and install all necessary pipe, valves, and fittings to create and connect from each boiler supply and return to the secondary loop low loss tees.
- 7) Supply and install all necessary pipe, valves, and fittings to connect existing propane gas, condensate neutralizer and drains to new boiler.
- 8) Supply and install all necessary PVC pipe and fittings for new exhaust vents to penetrate roof through the existing 16" double wall stack.
- 9) Supply and install new fiberglass insulation with ASJ (all service jacket) on new system piping from new boiler to tie ins to existing system piping.
- 10) Supply necessary electrical hardware to connect existing electrical to new boilers and boilers circulator.
- 11) Start new boiler on propane gas and adjust for proper combustion and temperatures. Check controls for proper operation. Provide training to necessary personnel.

We hereby propose to furnish material and labor complete in accordance with the above proposed scope of work for the sum of:

One Hundred Seventy-Four Thousand Six Hundred Ninety-Four Dollars and 00/100 \$174,694.00

Capitol Boiler Works

Building Efficiency and Sustainability

A Service Logic Company

Page 2 of 2
L23-0371

- All work to be done during normal business hours Monday thru Friday 6:30 am to 2:30 pm.
- Overtime, Sundays and holidays are excluded.
- All work will be done in a safe and timely manner by skilled journeymen during normal working hours and all work areas will be left in a broom clean condition. All debris generated by the execution of the scope of work will be removed from the property and properly disposed.

All labor and materials carry our limited one (1) year warranty. Thank you for the opportunity of quoting. All invoice disputes must be emailed to ardispute@capitolboilerworks.com within 10 days of the invoice date, otherwise the invoice is due in full as per the terms of your proposal.

Price valid for 30 days. PAYMENT TERMS:

Contract Terms	%	
Acceptance	35	Due: Upon Acceptance.
Progress Billing	50	Progress billing upon delivery of Equipment: Due: Net 30
Job Completion	15	Will be invoiced when the job is complete. Due: Net 30

Anthony W. Bendall

Sales Engineer, Anthony W. Bendall

Acceptance of Proposal:

The prices, specifications and conditions are satisfactory and are hereby accepted. You are authorized to do the work specified. Payment will be made as outlined above.

Signature _____

Date _____

Print Name _____

Title _____

Northumberland County Draft Capital Improvement Program Project Form

<p>(1) Office/Department NCPs Maintenance Department</p>	
<p>(2) Project Title Urgent Necessary Desirable</p> <p style="text-align: center;">Project Priority: Urgent Year Required: 2023</p>	
<p>(3) Project Description (include sketches, appraisals, plans, etc.) The existing exterior walkways at NMS/NHS currently consist of poured slabs that wrap large areas of concrete pavers. Over time the concrete pavers have settled, leaving numerous trip hazards around the exterior walkways of this facility. The most cost effective means to correct this is to remove the concrete pavers and replace with a poured concrete slab to level all walking surfaces. The areas where the pavers are removed can be stamped to mimic the original appearance.</p> <p>Attachment # Copy of NMS-NHS Concrete walkway quote-Ricky Elam-rev 02.pdf</p>	
<p>(4) Project Justification (includes ramifications if project is not implemented) The School System was notified by VOSH that an employee filed a complaint in regards to the current safety issues involved with having numerous uneven surfaces.</p> <p>Attachment # VOSH Response.pdf</p>	
<p>(5) Cost (include staffing needs, annual O&M requirements, planning/engineering, equipment/furniture, acquisition, construction) Cost, as per the quote from Ricky Elam attached, for a stamped concrete slab to replace all existing pavers is \$70,860.00. Unstamped is \$53,145.</p>	
<p>(6) Funding Source(s)</p> <p>Current Revenue Grant (Type) Revenue Bond Loan (Type) General Obligation Bond Special Assessment Capital Reserve Fund Other</p>	

Requestor Date

Planning Commission Meeting

Date/Time

Planning Commission Comments:

Ricky Elam Concrete Construction
15277 Richmond Road
Callao, VA 22435
(804) 529-7636 450-1329

Date 9/20/22

To Northumberland Schools

Address Academics Lane

Phone # Attn: Jeff Brann

RECC Proposal to Furnish All Material and Labor for
 (Description of work)

<u>Remove Pavers and pour 4" concrete. Walkways</u>		
	<u>Stamped</u>	<u>Regular</u>
<u>Middle School</u>	<u>\$70,860.⁰⁰</u>	<u>\$53,115.⁰⁰</u>
<u>High School</u>	<u>\$12,480.⁰⁰</u>	<u>\$9,360.⁰⁰</u>
<u>Door 18</u>	<u>\$28,500.⁰⁰</u>	<u>\$21,375.⁰⁰</u>

Pattern _____

Color _____

Total Price \$ _____
 (Quote good for 30 Days)

By _____
 (Officer of RECC)

Terms of Payment:

Down payment: _____ % \$ _____

Balance Due upon Completion \$ _____

Accepted this _____ Day of _____, 20____

By _____
 (Owner or Contractor)



COMMONWEALTH of VIRGINIA

DEPARTMENT OF LABOR AND INDUSTRY
CENTRAL REGIONAL OFFICE

Gary G. Pan
COMMISSIONER

North Run Business Park
1570 East Parham Road
Richmond, Virginia 23228
Phone: (804) 371-3104
Fax: (804) 371-3166

September 8, 2022

Northumberland High School
Attn: Adam Letizia, Compliance Officer
P.O. Box 730
6798 Northumberland Highway
Heathsville, VA 22473

SUBJECT: Northumberland High School
201 Academic Lane
Heathsville,, VA 22473
Complaint Number 1939074

Dear Mr. Letizia:

On August 29, 2022, the Virginia Occupational Safety and Health (VOSH) Program notified you of alleged safety and/or health hazards at your worksite.

Your response to these allegations was received in the Regional Office on September 1, 2022.

Based on our review of the information you provided in your response to these alleged hazards, we have determined that our file on this matter can be closed and no further action on this complaint is anticipated at this time.

Please note, however, that the complainant will also be given the opportunity to review the information provided in your response. If the complainant disputes the accuracy of the response, it may be necessary for VOSH to contact you for additional information or documentation of corrective action in order to resolve these issues. In some situations, it may be necessary to conduct an inspection of your workplace.

Please note that Va. Code §40.1-51.2:1 states that no persons shall discharge or in any way discriminate against an employee because the employee has filed a safety or health complaint or has testified or has otherwise acted to exercise his/her rights under the safety and health provisions under this Title for themselves or others. Adverse action taken against an employee who has filed a complaint or has engaged in an occupational safety and health activity protected by the Labor Laws of Virginia can result in a VOSH onsite inspection.

The State of Virginia offers VOSH Consultation services without charge, to assist in resolving all occupational safety and health issues. However, the variety of services available or the scheduling of those services may be limited by the VOSH Consultation Program's requirement to give priority to small businesses in high hazard industries and by its backlog. To discuss or request the services, please contact:

Consultation Program Manager
804.786.8707

We appreciate your prompt response to these allegations, and your interest in the safety and health of your employees. Please feel free to contact this office if we can be of additional assistance to you.

Sincerely,

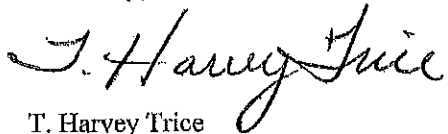
A handwritten signature in cursive script that reads "T. Harvey Trice".

T. Harvey Trice
Central Region Safety Director
Virginia Occupational Safety and Health
harvey.trice@doli.virginia.gov

/TE

Northumberland County Draft Capital Improvement Program Project Form

<p>(1) Office/Department: NCPS Maintenance Department</p>	
<p>(2) Project Title Urgent Necessary Desirable:</p> <p style="text-align: center;">Project Priority: Urgent Year Required: 2025</p>	
<p>(3) Project Description (include sketches, appraisals, plans, etc.) NCPS is required to abandon either the High School/Middle School or Elementary School Well no later than March 1, 2026. A new well shall be dug to replace the abandoned well</p> <p>Attachment #</p>	
<p>(4) Project Justification (includes ramifications if project is not implemented) The Department of Environmental Quality(DEQ) requires that NCPS shall properly abandon either the High School Well(DEQ#166-00133) or the Elementary School Well(DEQ#166-00163) in accordance with the Virginia Department of Health's Regulations no later than March 1, 2026.</p> <p>Attachment # DEQ Existing User Permit.pdf</p>	
<p>(5) Cost (include staffing needs, annual O&M requirements, planning/engineering, equipment/furniture, acquisition, construction) \$450,000</p>	
<p>(6) Funding Source(s)</p> <p>Current Revenue Grant (Type) Revenue Bond Loan (Type) General Obligation Bond Special Assessment Capital Reserve Fund Other</p>	

Requestor Date

Planning Commission Meeting

Date/Time

Planning Commission Comments:



COMMONWEALTH of VIRGINIA
 DEPARTMENT OF ENVIRONMENTAL QUALITY
EXISTING USER PERMIT
 TO WITHDRAW GROUNDWATER IN THE
 EASTERN VIRGINIA GROUNDWATER MANAGEMENT AREA

Permit Number: GW00111EU

Effective Date: March 1, 2017

Expiration Date: February 28, 2027

Pursuant to Section 62.1-256 of the Ground Water Management Act of 1992 (Chapter 25, Title 62.1 of the Code of Virginia) and the Groundwater Withdrawal Regulations (Regulations)(9VAC25-610-10 *et seq.*), the State Water Control Board (Board) hereby authorizes the Permittee to withdraw and use groundwater in accordance with this permit.

Permittee	<u>Northumberland County School Board</u>
Facility	<u>Northumberland County Schools</u>
Facility Address	<u>201 Academic Lane</u>
	<u>Heathsville, VA 22473</u>

The Permittee's authorized groundwater withdrawal shall not exceed:

<u>5,000,000</u>	gallons per year
<u>800,000</u>	gallons per month
<u>272,480</u>	gallons per day

The permitted withdrawal will be used to provide a non-municipal public water supply. Other uses are not authorized by this permit.

The Permittee shall comply with all conditions and requirements of the permit.

By direction of the State Water Control Board, this Permit is granted by:

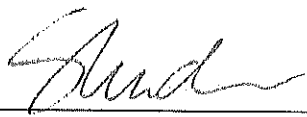
Signed 

Date 3/1/17

Director, Office of Water Supply

This permit is based on the Permittee's application submitted on March 24, 2014, and subsequently amended to include supplemental information provided by the Permittee. The following are conditions applicable to all permits and govern the system set-up and operation, monitoring, reporting, and recordkeeping pertinent to the Regulations.

**Part I
Operating Conditions**

A. Authorized Withdrawal

1. The withdrawal of groundwater shall be limited to the following wells identified in the table below. Withdrawals from wells not included in Table 1 are not authorized by this permit and are therefore prohibited. 9VAC25-610-140(A)

Table 1

<i>Owner Well Name</i>	<i>DEQ Well No.</i>	<i>Well Depth (ft.)</i>	<i>Screen Intervals (ft.)</i>	<i>Aquifer*</i>	<i>Latitude</i>	<i>Longitude</i>
High School	166-00133	760	620-640, 655-675 700-715, 740-750	Not determined	37° 54' 48.41"	76° 26' 14.64"
Elementary School	166-00163	828	610-620, 640-660 760-740, 810-820	Not determined	37° 54' 18.24"	76° 26' 30.22"

*Review of available geophysical logs has not yet been conducted to make this determination.

2. Any actions that result in a change to the status, construction, or pump intake setting of wells included in this permit must be pre-approved by the Department of Environmental Quality (Department) in writing prior to implementing the change, and a revised GW-2 Form must be submitted to the Department within 30 days after the physical construction of a well is altered or the pump intake setting has been changed. If changes are a result of an emergency, notify the Department within 5 days from the change. 9VAC25-610-140(C)

B. Public Water Supplies

1. Daily withdrawal limits set forth in this permit are consistent with the requirements and conditions of the Virginia Department of Health Waterworks Operation Permit Nos. 4133630 and 4133622. 9VAC25-610-140(A)(5)
2. The Permittee shall submit copies of an updated Waterworks Operation Permit and the associated Engineering Description Sheets to the Department within 30 days of receipt from the Virginia Department of Health. 9VAC25-610-140(C)

C. Pump Intake Settings

The Permittee shall not knowingly place a pump or water intake device lower than the top of the uppermost confined aquifer that a well utilizes as a groundwater source or lower than the bottom of an unconfined aquifer that a well utilizes as a groundwater source in order to prevent dewatering of the aquifer, loss of inelastic storage, or damage to the aquifer from compaction. 9VAC25-610-140(A)(6)

D. Withdrawal Reporting

1. Water withdrawn from each well shall be recorded monthly at the end of each month and reported to the Groundwater Withdrawal Permitting Program, in a paper or electronic format provided by the Department, by the tenth (10th) day of each January, April, July and October for the respective previous standard quarter. Records of water use shall be maintained by the Permittee in accordance with Part III, Condition F, of this permit. 9VAC25-610-140(A)(9)
2. The Permittee shall report any amount in excess of the permitted withdrawal limit by the fifth (5th) day of the month following the month when such a withdrawal occurred. Failure to report may result in compliance or enforcement activities. 9VAC25-610-140(C)

E. Well Tags

1. Each well that is included in this permit shall have affixed to the well casing, in a prominent place, a permanent well identification plate that records, at a minimum, the DEQ well identification number, the groundwater withdrawal permit number, the total depth of the well, and the screened intervals in the well. Such well identification plates shall be in a format specified by the Board and are available from the Department. 9VAC25-610-140(12)
2. Well tags shall be affixed to the appropriate well casing within 30 days of receiving the tags from the Department. The accompanying well tag installation certification form shall be returned to the Department within 60 days of receipt of the tags. 9VAC25-610-140(C)

Part II Special Conditions

Pursuant to 9VAC25-610-140(B) and (C), the following Special Conditions apply to this permit in order to protect the public welfare, safety, and health or conserve, protect and help ensure the beneficial use of groundwater.

A. Well Abandonment

1. Within three (3) years of the effective date of this permit (March 1, 2020), the Permittee shall investigate the abandonment status of the old Middle School Well (aka old Central High School Well) (DEQ well #166-00070). If the well is found to not have been permanently abandoned, the Permittee is to conduct the permanent abandonment of the well following Virginia Department of Health requirements and submit documentation of the actions to Department within 30 days of the completion. At least two weeks prior to the scheduled abandonment, the Permittee shall notify the Department of the scheduled abandonment date.
2. Within nine (9) years of the effective date of this Permit (March 1, 2026), the Permittee shall properly abandon either the High School Well (DEQ #166-00133) or the Elementary School Well (DEQ #166-00163) in accordance with the Virginia Department of Health's Regulations and submit documentation to the Department of Environmental Quality within 30 days of abandonment. At least two weeks prior to the scheduled abandonment, the Permittee shall notify the Department of the scheduled abandonment date.

B. Pump Intake Depth Determination and/or Reset

Prior to a request for expansion or renewal, and no later than (June 3, 2026), the Permittee shall ensure that the pump intake depths for all wells are set above the maximum pump setting depth as provided by Department staff based on new geophysical log data obtained by the Permittee. At least two weeks prior to the scheduled pump intake determinations; the Permittee shall notify the Department of the work schedule. The Permittee shall advise DEQ, in writing, of the pump setting within 30 days of the depth determination or pump depth adjustment.

C. Water Conservation and Management

The Permittee has committed to submitting an approvable Water Conservation and Management Plan meeting the requirements of 9VAC25-610-100 within two years of the effective date of this permit and has agreed to have the plan incorporated into the permit. Once an approvable plan is received by the Department, the permit will be modified to include a water savings allotment of 500,000 gallons added to the currently permitted limit and the Plan will be incorporated into the permit as a permit condition.

**Part III
General Conditions**

A. Duty to Comply

The Permittee shall comply with all conditions of this permit. Nothing in this permit shall be construed to relieve the permit holder of the duty to comply with all applicable federal and state statutes, regulations and prohibitions. Any permit violation is a violation of the law and is grounds for enforcement action, permit termination, revocation, modification, or denial of a permit application.
9VAC25-610-130(A)

B. Duty to Cease or Confine Activity

It shall not be a defense for a Permittee in an enforcement action that it would have been necessary to halt or reduce the activity for which a permit has been granted in order to maintain compliance with the conditions of the permit. 9VAC25-610-130(B)

C. Duty to Mitigate

The Permittee shall take all reasonable steps to avoid all adverse impacts that may result from this withdrawal as defined in 9VAC25-610-10 and provide mitigation of the adverse impact when necessary as described in 9VAC25-610-110(D)(3)(g). 9VAC25-610-130(C)

D. Inspection, Entry, and Information Requests

Upon presentation of credentials, the Permittee shall allow the Board, the Department, or any duly authorized agent of the Board, at reasonable times and under reasonable circumstances, to enter upon the Permittee's property, public or private, and have access to, inspect and copy any records that must be kept as part of the permit conditions, and to inspect any facilities, well(s), water supply system, operations, or practices (including sampling, monitoring and withdrawal) regulated or required under the

permit. For the purpose of this section, the time for inspection shall be deemed reasonable during regular business hours. Nothing contained herein shall make an inspection time unreasonable during an emergency. 9VAC25-610-130(D)

E. Duty to Provide Information

The Permittee shall furnish to the Board or Department, within a reasonable time, any information that the Board may request to determine whether cause exists for modifying or revoking, reissuing, or terminating the permit, or to determine compliance with the permit. The Permittee shall also furnish to the Board or Department, upon request, copies of records required to be kept by regulation or this permit. 9VAC25-610-130(E)

F. Monitoring and Records Requirements

1. The Permittee shall maintain a copy of the permit on-site and/or shall make the permit available upon request. 9VAC25-610-130(E)
2. Monitoring of parameters shall be conducted according to approved analytical methods as specified in the permit. 9VAC25-610-130(F)(1)
3. Samples and measurements taken for the purpose of monitoring shall be representative of the monitored activity. 9VAC25-610-130(F)(2)
4. The Permittee shall retain records of all monitoring information, including all calibration and maintenance records and all original strip chart or electronic recordings for continuous monitoring instrumentation, copies of all reports required by the permit, and records of all data used to complete the application for the permit, for a period of at least three years from the date of the expiration of a granted permit. This period may be extended by request of the Board at any time. 9VAC25-610-130(F)(3)
5. Records of monitoring information shall include as appropriate (9VAC25-610-130(F)(4)):
 - a. The date, exact place and time of sampling or measurements;
 - b. The name(s) of the individual(s) who performed the sampling or measurements;
 - c. The date the analyses were performed;
 - d. The name(s) of the individual(s) who performed the analyses;
 - e. The analytical techniques or methods supporting the information, such as observations, readings, calculations and bench data used;
 - f. The results of such analyses; and
 - g. Chain of custody documentation.

G. Environmental Laboratory Certification

The Permittee shall comply with the requirement for certification of laboratories conducting any tests, analyses, measurements, or monitoring required pursuant to the State Water Control Law (§ 62.1-44.2 et seq.), Environmental Laboratory Certification Program (§ 2.2-1105 *et seq.*), Certification for Noncommercial Environmental Laboratories (1VAC30-45), and/or Accreditation for Commercial Environmental Laboratories (1VAC30-46), and:

- a. Ensure that all samples and measurements taken for the purpose of monitoring shall be representative of the monitored activity.
- b. Conduct monitoring according to procedures approved under 40CFR Part 136 or alternative methods approved by the U.S. Environmental Protection Agency.
- c. Periodically calibrate and perform maintenance procedures on all monitoring and analytical instrumentation at intervals that will ensure accuracy of measurements. (1VAC30-45-20)

H. Future Permitting Actions

1. A permit may be modified or revoked as set forth in Part VI of the Regulations. 9VAC25-610-290 and 9VAC25-610-130(G)
2. If a Permittee files a request for permit modification or revocation, or files a notification of planned changes, or anticipated noncompliance, the permit terms and conditions shall remain effective until the Board makes a final case decision. This provision shall not be used to extend the expiration date of the effective permit. 9VAC25-610-130(G)
3. Permits may be modified or revoked upon the request of the Permittee, or upon Board initiative, to reflect the requirements of any changes in the statutes or regulations. 9VAC25-610-130(G)
4. The Permittee shall schedule a meeting with the Department prior to submitting a new, expanded or modified permit application. 9VAC25-610-85
5. A new permit application shall be submitted 270 days prior to any proposed modification to this permit (i) that will result in an increase of withdrawal above permitted limits or violate the terms and conditions of this permit; or (ii) to continue a withdrawal greater than 300,000 gallons in any month while an application for renewal is being processed. 9VAC25-610-96
6. The Permittee shall provide all information described in 9VAC25-610-94 for any reapplication. 9VAC25-610-96(C)
7. The Permittee must notify the Department in writing of any changes to owner and facility contact information within 30 days of the change. 9VAC25-610-140 (C)

I. Metering and Equipment Requirements

1. Each well and/or impoundment or impoundment system shall have installed an in-line totalizing flow meter to read gallons, cubic feet, or cubic meters on each permitted well prior to beginning the permitted use. Meters shall produce volume determinations within plus or minus 10% of actual flows. 9VAC25-610-140(7)(A)(b)
 - a. A defective meter or other device must be repaired or replaced within 30 days.
 - b. A defective meter is not grounds for not reporting withdrawals. During any period when a meter is defective, generally accepted engineering methods shall be used to estimate withdrawals. The period during which the meter was defective must be clearly identified in the groundwater withdrawal report required by Part I, Subsection D of this permit. An alternative method for determining flow may be approved by the Board on a case-by-case basis.

2. Each well shall be equipped in a manner such that water levels can be measured during pumping and non-pumping periods without dismantling any equipment. Any opening for tape measurement of water levels shall have an inside diameter of at least 0.5 inches and be sealed by a removable plug or cap. The Permittee shall provide a tap for taking raw water samples from each permitted well. 9VAC25-610-140(A)(7)(e)

J. Minor Modifications

1. A minor modification to this permit must be made to replace an existing well(s) or add an additional well(s) provided that the well(s) is screened in the same aquifer(s) as the existing well(s) and is in the near vicinity of the existing well(s), the total groundwater withdrawal does not increase, the area of impact does not increase, and the well has been approved by the Department prior to construction. 9VAC25-610-330(B)(4) and (5)
2. A minor modification to this permit must be made to combine withdrawals governed by multiple permits when the systems are physically connected as long as interconnection will not result in additional groundwater withdrawal and the area of impact will not increase. 9VAC25-610-330(B)(6)
3. Minor modifications to this permit must also be made to.
 - a. Change an interim compliance date up to 120 days from the original compliance date, as long as the change does not interfere with the final compliance date. 9VAC25-610-330(B)(7)
 - b. Allow for change in ownership when the Board determines no other change in the permit is necessary and the appropriate written agreements are provided in accordance with the transferability of permits and special exceptions. 9VAC25-610-320 and 9VAC25-610-330(B)(8)
 - c. Revise a Water Conservation and Management Plan to update conservation measures being implemented by the Permittee that increase the amount of groundwater conserved. 9VAC25-610-330(B)(9)

K. Well Construction

At least two weeks prior to the scheduled construction of any well(s), the Permittee shall notify the Department of the construction timetable and receive prior approval of the well(s) location(s) and acquire the DEQ Well number. All wells shall be constructed in accordance with the following requirements.

1. A well site approval letter or well construction permit must be obtained from the Virginia Department of Health prior to construction of the well. 9VAC25-610-130(A)
2. A complete suite of geophysical logs (Spontaneous Potential, Single Point Resistance, 16/64 Short and Long Normal, Natural Gamma) shall be completed for the well and submitted to the Department along with the corresponding completion report. 9VAC25-610-140(C)
3. The Permittee shall evaluate the geophysical log and driller's log information to estimate the top of the target aquifer, and therefore, a depth below which the pump shall not be set. The Permittee's determination of the top of the target aquifer shall be submitted to the Department for review and approval, or approved on site by the Department's Groundwater Characterization staff, prior to installation of any pump. 9VAC25-610-140 (A)(6)
4. The Permittee shall install gravel packs and grout in a manner that prevents leakage between

aquifers. Gravel pack shall be terminated close to the top of the well screen(s) and shall not extend above the top of the target aquifer. 9VAC25-610-140(C)

5. A completed GW-2 Form and any additional water well construction documents shall be submitted to the Department within 30 days of the completion of any well and prior to the initiation of any withdrawal from the well. 9VAC25-610-140(C)
6. The assigned DEQ well number shall be included on all well documents. 9VAC25-610-140(C)

L. Permit Reopening

This permit may be reopened for the purpose of modifying the conditions of the permit as follows:

1. To meet new regulatory standards duly adopted by the Board. 9VAC25-610-140(A)(11)
2. When new information becomes available about the permitted withdrawal, or the impact of the withdrawal, which had not been available at permit issuance and would have justified the application of different conditions at the time of issuance. 9VAC25-610-310(B)(1)
3. When the reported withdrawal is less than 60% of the permitted withdrawal amount for a five year period. 9VAC25-610-310(B)(2)
4. If monitoring information indicates the potential for adverse impacts to groundwater quality or level due to this withdrawal. 9VAC25-610-140(C)

Part IV Items needed for Re-Application, Expansion, or Modification

To ensure uninterrupted operation of the Permittee's withdrawal system, a complete application must be submitted 270 days prior to the expiration date of this permit (June 3, 2026) or the start of a proposed modification. The following is a list of items or actions that, along with the completed application, will be required, at a minimum, to ensure an application would be deemed complete. 9VAC25-610-10 *et seq.*



1. A pre-application meeting with Department staff
2. A Water Conservation and Management Plan

A Water Conservation and Management Plan (WCMP) is an operational plan and shall be consistent with local and regional water supply plans in the Permittee's geographic area. The WCMP shall be specific to the type of water use and include the following: 9VAC25-610-100(B)

- a. Requirements for the use of water saving equipment and processes to ensure the most efficient use of groundwater and decrease the water demand;
- b. A water loss reduction program which defines the applicant's leak detection and repair program;
- c. A water use education program which contains requirements for the education of water users and training of employees controlling water consuming processes to assure that water conservation principles are well known by the users of the resource;
- d. An evaluation of potential water reuse options and assurances that water shall be reused in all

- instances where reuse is practicable and not prohibited by other regulatory programs;
- e. Requirements for mandatory water use reductions and compliance with restrictions during water shortage emergencies declared by the local governing body or water authority consistent with §§ 15.2-923 and 15.2-924 of the Code of Virginia. This should include, where appropriate, ordinances in municipal systems prohibiting the waste of water generally and requirements providing for mandatory water use restrictions in accordance with drought response and contingency ordinances implemented to comply with 9VAC25-780-120 during water shortage emergencies. Penalties for failure to comply with mandatory water use restrictions should be included in municipal system plans.
3. Evaluation of potential alternative water sources, including potential reuse sources, storm water capture, and surface water sources, municipal supplies, etc.
 4. Signed Local Government Ordinance Form (LGOF). This is a form supplied by the Department that the applicant sends to the local governing body in which the withdrawal is to occur, to obtain notification that the location and operation of the withdrawing facility is in compliance with all ordinances adopted pursuant to Chapter 22 (§ 15.2-2200 *et seq.*) of Title 15.2 of the Code of Virginia.
 5. Mitigation Plan. This is a plan to mitigate potential adverse impacts from the proposed withdrawal on existing groundwater users for systems where the predicted area of impact extends beyond the property owned by the Permittee.
 6. Permit fee for non-agricultural applicants

Northumberland County Draft Capital Improvement Program Project Form

<p>(1) Office/Department NCPS Maintenance Department/IT Department</p>	
<p>(2) Project Title Urgent Necessary Desirable NCPS INTEGRATED SECURITY PACKAGE</p> <p style="text-align: center;">Project Priority : Urgent Year Required: 2024</p>	
<p>(3) Project Description (include sketches, appraisals, plans, etc.) Replace the existing security camera system, building access card swipe system, emergency access lockdown system with an integrated security package.</p> <p>Attachment #</p>	
<p>(4) Project Justification (includes ramifications if project is not implemented) NCPS currently has several companies providing various safety and access controls systems. These systems do not work in conjunction with one another and require separate licenses that are very costly. An integrated system will require only one license to allow for one application to control all features. This allows for significant cost savings over the life of the system.</p> <p>Attachment #  Northumberland Elementary.pdf  Northumberland HS_MS.pdf</p>	
<p>(5) Cost (include staffing needs, annual O&M requirements, planning/engineering, equipment/furniture, acquisition, construction)\$653,981.38</p>	
<p>(6) Funding Source(s)</p> <p>Current Revenue Grant (Type) Revenue Bond Loan (Type) General Obligation Bond Special Assessment Capital Reserve Fund Other</p>	

Requestor Date

Planning Commission Meeting

Date/Time

Planning Commission Comments:



Customer

Epitome Networks
4201 Park Place Court
Glen Allen, VA
23060, US
(804) 419-8300 DCJS: 11-6608

Northumberland County Schools
2172 Northumberland Highway
Lottsburg, Virginia
22511, United States

Travis Burns

Prepared By:
Bill Deutsch
(804) 388-3001
bdeutsch@epitomenetworks.com

tburns@nucps.net

Project: Northumberland Elementary School Security

Scope of Work

Epitome Networks will provide and install an integrated Verkada Security System for the Northumberland County Elementary School.

Executive Summary

The security package for Northumberland County has been designed to control cameras, building access, and intercoms. All systems will be monitored and programmed from a single interface, with any internet connected device. In order to limit ongoing operating expenses, all Verkada devices are licensed and warranted for a full 10 years. Licensing includes 24/7 online tech support and rapid equipment replacement for 10 years.

Video Surveillance

The surveillance system includes the capability to detect suspicious activity indicating theft or vandalism and create watch lists for persons of interest. Users can quickly search video based on faces or attributes such as motion, and clothing or vehicle color. This will allow the school to efficiently investigate incidents. All video will be stored for thirty days. Footage can be downloaded and stored indefinitely. All cameras can be quickly shared with Law Enforcement to provide full situational awareness in an emergency. The following cameras are included.

- (1) surface mounted multisensor camera to view north courtyard area
- (2) surface mounted multisensor cameras to view school entrances and drive-up loops
- (1) surface mounted multisensor cameras to view south entrance
- (1) pendant mounted dome camera to view playground
- (4) canopy mounted dome cameras to view building entrances
- (1) canopy mounted fisheye camera to view loading area
- (54) ceiling mounted dome cameras to replace existing interior cameras
- (1) viewing station for office

Intercom

The intercom system includes an audio/video intercom at the main entrance. Intercom will provide 2-way communication and door release from desktop computer or mobile device. Intercom includes a fully functioning surveillance camera to provide an overview of activity at the entrance.

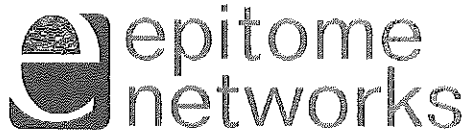

Note: This is a budgetary quote based on initial site survey. Final review of camera and equipment replacement is required prior to finalized quote.

Video Surveillance

	Quantity	Unit Cost	Total Cost
CD42 Indoor Dome Camera Description: 256GB, 30 Day Storage, 5MP	54 ea	\$ 749.26	\$ 40,460.31
CD42-E Outdoor Dome Camera Description: 256GB, 30 Days Storage, 5 MP, 2.8mm	5 ea	\$ 899.27	\$ 4,496.34
CH52 Multisensor Camera Description: 2TB, 60 Days Storage, 4 x 5MP, 3.7-4.7mm	4 ea	\$ 2,699.30	\$ 10,797.22
ACC-MNT-2 Description: Mounting Arm Kit	4 ea	\$ 66.75	\$ 267.01
ACC-MNT-3 Description: L Bracket Mount	1 ea	\$ 96.75	\$ 96.75
ACC-MNT-8 Description: Pendant Cap	4 ea	\$ 51.75	\$ 207.00
CF81-E Fisheye Camera Description: 512GB, 30 Days Storage, 180 Degree Panoramic View	1 ea	\$ 1,499.28	\$ 1,499.28
VX52 Viewing Station	1 ea	\$ 374.26	\$ 374.26
LIC-CH52-10Y Description: 10-Year Multisensor Camera License	4 ea	\$ 4,049.33	\$ 16,197.32
LIC-10Y Description: 10 Year Camera License	60 ea	\$ 1,349.28	\$ 80,956.62
LIC-VX-10Y Viewing Station License	1 ea	\$ 2,999.31	\$ 2,999.31
Patch Cord 7' Description: Yellow, Reduced Diameter, Booted Snagless	64 ea	\$ 5.85	\$ 374.40
77-240-5B Cat 6 Cable Description: Cable, Category 6, CMP, Green, 1,000'	19 ea	\$ 420.00	\$ 7,980.00
Misc Installation Hardware Description: J-hooks, ceiling hanger wire, weather sealant, firestop material, etc.	1 ea	\$ 6,900.00	\$ 6,900.00
Installation Labor *	1 ea	\$ 36,480.00	\$ 36,480.00
Lift Rental	1 ea	\$ 3,495.00	\$ 3,495.00
	--	--	\$ 213,580.82

Access Control

	Quantity	Unit Cost	Total Cost
AC41-HW 4-Door Controller Description: 4-Door Access Control Panel	1 ea	\$ 1,349.28	\$ 1,349.28



	Quantity	Unit Cost	Total Cost
AD33 Door Reader	3 ea	\$ 261.76	\$ 785.27
Description: Single Gang or Mullion Mount Reader, Low and High Frequency			
LIC-AC-10Y	3 ea	\$ 1,499.28	\$ 4,497.84
Description: 10 Year Cloud License (Per Door)			
Installation Labor	1 ea	\$ 855.00	\$ 855.00
	--	--	\$ 7,487.38

Intercom

	Quantity	Unit Cost	Total Cost
TD52 Video Intercom	1 ea	\$ 1,199.27	\$ 1,199.27
Description: 256GB, 5MP, 2.12mm Lens, 90dB Speaker			
ACC-INT-SURF Bracket	1 ea	\$ 149.25	\$ 149.25
Description: Surface Mount Bracket for Intercom			
LIC-TX-10Y Desk Station App License	1 ea	\$ 1,499.28	\$ 1,499.28
Description: 10-Year Desk Station App License			
LIC-TD-10Y Intercom License	1 ea	\$ 1,499.28	\$ 1,499.28
Description: 10-Year Video Intercom License			
Installation Labor	1 ea	\$ 380.00	\$ 380.00
	--	--	\$ 4,727.09

* Tax not applied to part or subcomponent

Excluded(-)

1. Fire Alarm Relays
2. Badges and Printing
3. Switches and Patch Panels

Notes

This Scope of work and pricing is confidential, and cannot be provided to any other Company, Entity, or Individual without prior written authorization from Epitome Networks. This Pricing is based on "Non-Union" or "Non-prevailing Wage" labor. Permit research, fees, and inspections are out of scope and will require a change order to be executed prior to any onsite installation services performed. Pricing is inclusive of travel and Epitome Networks Project Coordination. Any changes to this Scope of work may require additional charges. If any changes occur that are outside of Epitome Networks' control, causing additional labor, and/or materials, it will be brought to the Customer Project team's attention via email for review and approval to proceed. Taxes, Shipping, Handling and other fees may apply. All applicable Taxes and Shipping charges will be added at the time of Final invoice.

Payment Terms: Invoices will be sent for all hardware at time of shipment. Services will be invoiced upon project completion, or if the project is delayed by more than 5 business days, we may invoice for work completed to date. Signature of this quote or issuance of a Purchase Order indicates acceptance of the terms outlined above.

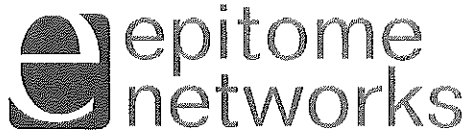

Quote: 5424 / Date: 7/12/2023

Summary

Price	
Labor and Adjustments	\$ 37,715.00
Materials	\$ 188,080.29
Subtotal	\$ 225,795.29

\$ 225,795.29

Accepted By

Date

.....



Quote: 5398 / Date: 7/12/2023

Customer

Epitome Networks
4201 Park Place Court
Glen Allen, VA
23060, US
(804) 419-8300 DCJS: 11-6608

Northumberland County Schools
2172 Northumberland Highway
Lottsburg, Virginia
22511, United States

Travis Burns

Prepared By:
Bill Deutsch
(804) 388-3001
bdeutsch@epitomenetworks.com

tburns@nucps.net

Project: Northumberland High School/Middle School Security

Scope of Work

Epitome Networks will provide and install an integrated Verkada Security System for the Northumberland County Middle and High Schools.

Executive Summary

The security package for Northumberland County has been designed to control cameras, building access, intercoms, and air quality. All systems will be monitored and programmed from a single interface, with any internet connected device. In order to limit ongoing operating expenses, all Verkada devices are licensed and warranted for a full 10 years. Licensing includes 24/7 online tech support and rapid equipment replacement for 10 years.

Video Surveillance

The surveillance system includes the capability to detect suspicious activity indicating theft or vandalism and create watch lists for persons of interest. Users can quickly search video based on faces or attributes such as motion, and clothing or vehicle color. This will allow the school to efficiently investigate incidents. All video will be stored for thirty days. Footage can be downloaded and stored indefinitely. All cameras can be quickly shared with Law Enforcement to provide full situational awareness in an emergency. The following cameras are included.

- (2) corner mounted multisensor cameras to view northwest and southwest building perimeters
- (2) corner mounted multisensor cameras to view school entrances and drive-up loops
- (1) corner mounted multisensor camera to view loading area
- (3) pole mounted multisensor cameras to view parking lot
- (2) canopy mounted dome cameras to view north building entrances
- (1) pendant mounted multisensor camera to view theater
- (1) ceiling mounted fisheye camera to view music room seating
- (84) ceiling mounted dome cameras to replace existing interior cameras
- (2) viewing stations for High School and Middle School offices

Environmental Camera/Sensor Pairs

The environmental package includes air quality sensors installed in (12) restrooms to detect the presence of vaping. Sensors will be paired with ceiling mounted mini-dome cameras to indicate activity at restroom entrances during an alert.



Access Control

Epitome Networks will migrate (6) existing access controlled doors to the Verkada platform. New controllers and readers will be connected to existing power supplies and locking hardware.

Intercom

The intercom system includes audio/video intercoms at the High School and Middle School doors. Intercoms will provide 2-way communication and door release from desktop computer or mobile device. Intercoms include fully functioning surveillance cameras to provide an overview of activity at the entrances.

Note: This is a budgetary quote based on initial site survey. Final review of camera and equipment replacement is required prior to finalized quote.

Video Surveillance

	Quantity	Unit Cost	Total Cost
CD42 Indoor Dome Camera Description: 256GB, 30 Day Storage, 5MP	84 ea	\$ 749.26	\$ 62,938.26
CD42-E Outdoor Dome Camera Description: 256GB, 30 Days Storage, 5 MP, 2.8mm	2 ea	\$ 899.27	\$ 1,798.54
CH52 Multisensor Camera Description: 2TB, 60 Days Storage, 4 x 5MP, 3.7-4.7mm	9 ea	\$ 2,699.30	\$ 24,293.74
ACC-MNT-2 Description: Mounting Arm Kit	9 ea	\$ 66.75	\$ 600.76
ACC-MNT-8 Description: Pendant Cap	9 ea	\$ 51.75	\$ 465.76
ACC-MNT-9 Description: Pole Mount	3 ea	\$ 156.75	\$ 470.26
ACC-MNT-10 Description: Corner Mount	5 ea	\$ 149.25	\$ 746.26
CF81-E Fisheye Camera Description: 512GB, 30 Days Storage, 180 Degree Panoramic View	1 ea	\$ 1,499.28	\$ 1,499.28
VX52 Viewing Station	2 ea	\$ 374.26	\$ 748.51
LIC-CH52-10Y Description: 10-Year Multisensor Camera License	9 ea	\$ 4,049.33	\$ 36,443.98
LIC-10Y Description: 10 Year Camera License	87 ea	\$ 1,349.28	\$ 117,387.10
LIC-VX-10Y Viewing Station License	2 ea	\$ 2,999.31	\$ 5,998.62
NetWay4E1BTWP Description: 4-port Hardened 802.3bt 4PPoE Switch and Power Supply/Charger - NEMA4/4X, IP66 rated Outdoor enclosure.	3 ea	\$ 972.46	\$ 2,917.39

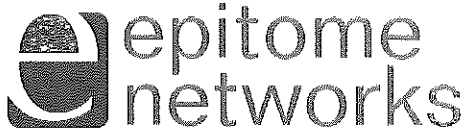

Intercom

	Quantity	Unit Cost	Total Cost
TD52 Video Intercom Description: 256GB, 5MP, 2.12mm Lens, 90dB Speaker	2 ea	\$ 1,199.27	\$ 2,398.55
ACC-INT-SURF Bracket Description: Surface Mount Bracket for Intercom	2 ea	\$ 149.25	\$ 298.51
LIC-TX-10Y Desk Station App License Description: 10-Year Desk Station App License	2 ea	\$ 1,499.28	\$ 2,998.56
LIC-TD-10Y Intercom License Description: 10-Year Video Intercom License	2 ea	\$ 1,499.28	\$ 2,998.56
Installation Labor	1 ea	\$ 760.00	\$ 760.00
	--	--	\$ 9,454.17

* Tax not applied to part or subcomponent

Excluded(-)

- 1. Fire Alarm Relays
- 2. Badges and Printing
- 3. Switches and Patch Panels

Notes

This Scope of work and pricing is confidential, and cannot be provided to any other Company, Entity, or Individual without prior written authorization from Epitome Networks. This Pricing is based on "Non-Union" or "Non-prevailing Wage" labor. Permit research, fees, and inspections are out of scope and will require a change order to be executed prior to any onsite installation services performed. Pricing is inclusive of travel and Epitome Networks Project Coordination. Any changes to this Scope of work may require additional charges. If any changes occur that are outside of Epitome Networks' control, causing additional labor, and/or materials, it will be brought to the Customer Project team's attention via email for review and approval to proceed. Taxes, Shipping, Handling and other fees may apply. All applicable Taxes and Shipping charges will be added at the time of Final invoice.

Payment Terms: Invoices will be sent for all hardware at time of shipment. Services will be invoiced upon project completion, or if the project is delayed by more than 5 business days, we may invoice for work completed to date. Signature of this quote or issuance of a Purchase Order indicates acceptance of the terms outlined above.

Summary

Price	
Labor and Adjustments	\$ 71,630.00
Materials	\$ 356,556.09
Subtotal	\$ 428,186.09



Quote: 5398 / Date: 7/12/2023

\$ 428,186.09

Accepted By

Date

.....



LEASE-FINANCE PROPOSAL

Date: July 12, 2023
Lessee: Northumberland County Public Schools
Equipment: Verkada Hardware, Software & Services
Lessor: Summit Funding Group, Inc.
Supplier: Epitome Networks
Project: Northumberland Elementary Schools Security

Table with 2 columns: Term, Acquisition Cost, Rate, Annual Payment, End of Term. Values include 2 years, \$233,093.10, 0.00%, \$116,546.55, and \$1 Buyout.

Indexing: The Lease Rate Factors are based on the U.S. 24 month Swap Rates as of July 12, 2023. Pricing will be adjusted upward or downward in proportion to increases in the Swap Rate to preserve Lessor's economics prior to lease commencement and will then fix for the term of the lease.

Insurance: Lessee will obtain and maintain all risk property insurance, comprehensive liability insurance, and all other insurance coverages requested by Lessor.

Conditions: This Proposal is not a commitment. Lessor's intent to enter into the transaction is conditioned upon (i) written credit approval (ii) no material adverse change in Lessee's or any Guarantor's business, prospects, assets, liabilities, or financial condition, (iii) no material adverse change in the domestic or international leasing, finance, capital, or syndication markets, (iv) inspection, appraisal, and approval of the Equipment by Lessor's asset management team, (v) execution and delivery of all agreements and documents requested by Lessor, and (vi) the satisfaction of all other conditions requested by Lessor.

This lease proposal expires on July 17, 2023.

Regards,

Handwritten signature of Adam R. Laughlin

Approved & Accepted by Northumberland County Public Schools

Adam R. Laughlin
Business Development Officer
SUMMIT FUNDING GROUP, INC.
www.summit-funding.com
Phone: (714) 856-7147
alaughlin@4sfq.com

Name:
Title:
Date:
FEIN/Tax ID



LEASE-FINANCE PROPOSAL

Date: July 12, 2023
Lessee: Northumberland County Public Schools
Equipment: Verkada Hardware, Software & Services
Lessor: Summit Funding Group, Inc.
Supplier: Epitome Networks
Project: Northumberland High School/Middle School Security

Table with 2 columns: Term, Acquisition Cost, Rate, Annual Payment, End of Term. Values include 2 years, \$442,025.28, 0.00%, \$221,012.64, and \$1 Buyout.

Indexing: The Lease Rate Factors are based on the U.S. 24 month Swap Rates as of July 12, 2023. Pricing will be adjusted upward or downward in proportion to increases in the Swap Rate to preserve Lessor's economics prior to lease commencement and will then fix for the term of the lease.

Insurance: Lessee will obtain and maintain all risk property insurance, comprehensive liability insurance, and all other insurance coverages requested by Lessor.

Conditions: This Proposal is not a commitment. Lessor's intent to enter into the transaction is conditioned upon (i) written credit approval (ii) no material adverse change in Lessee's or any Guarantor's business, prospects, assets, liabilities, or financial condition, (iii) no material adverse change in the domestic or international leasing, finance, capital, or syndication markets, (iv) inspection, appraisal, and approval of the Equipment by Lessor's asset management team, (v) execution and delivery of all agreements and documents requested by Lessor, and (vi) the satisfaction of all other conditions requested by Lessor.

This lease proposal expires on July 17, 2023.

Regards,

Handwritten signature of Adam R. Laughlin

Approved & Accepted by Northumberland County Public Schools

Adam R. Laughlin
Business Development Officer
SUMMIT FUNDING GROUP, INC.
www.summit-funding.com
Phone: (714) 856-7147
alaughlin@4sfg.com

Name:
Title:
Date:
FEIN/Tax ID

Northumberland County Draft Capital Improvement Program Project Form

<p>(1) Office/Department: NCPS Maintenance Department</p>	
<p>(2) Project Title Urgent Necessary Desirable</p> <p style="text-align: center;">Project Priority: Urgent Year Required: 2023</p>	
<p>(3) Project Description (include sketches, appraisals, plans, etc.) The Installation of a galvanized stairway system on the back of the facility, providing safe roof access.</p> <p>Attachment # Northumberland Elem School .pdf</p>	
<p>(4) Project Justification (includes ramifications if project is not implemented) Currently, NES only has a ladder located in the rear mechanical room to provide access to the roof. Technicians cannot transport heavy equipment, tools, etc via this ladder and this ladder poses a safety concern during inclement weather.</p>	
<p>(5) Cost (include staffing needs, annual O&M requirements, planning/engineering, equipment/furniture, acquisition, construction) \$63,756</p> <p>https://drive.google.com/file/d/1yoysTpAhkDEb9xDwNlxXkkBhhhc_EKwV/view?usp=drive_link</p>	
<p>(6) Funding Source(s)</p> <p>Current Revenue Grant (Type) Revenue Bond Loan (Type) General Obligation Bond Special Assessment Capital Reserve Fund Other</p>	

Requestor Date

Planning Commission Meeting

Date/Time

Planning Commission Comments:

HANOVER IRON AND STEEL, INC.

Hanover Industrial Air Park
 11149 Leadbetter Road
 ASHLAND, VA 23005
 798-5604 • 798-5200
 FAX 798-5260
 EMAIL hwebb64775@aol.com



JOB _____
 SHEET NO. _____ OF 1
 CALCULATED BY _____ DATE 7.7.22'
 CHECKED BY _____ DATE _____

MARK NUMBER LONG E.S.

SCOPE: FREE STANDING EXT. AIR STAIR ~ "CONC" CORROSION TREATMENT ~ 14 x 14" W/SLASHING PAINTED 2-LINE 14# ROIL W/ DROP ROIL BOTH SIDES x 3:6 MC 12 x 14.3 STRINGS TYPICAL T.S. 4 x 4 x 1/4 PANS W/ X-FRACING

ELEV = 12.22 ~ 32 RISES @ 4 1/2" STAIR WIDTH = 3:6

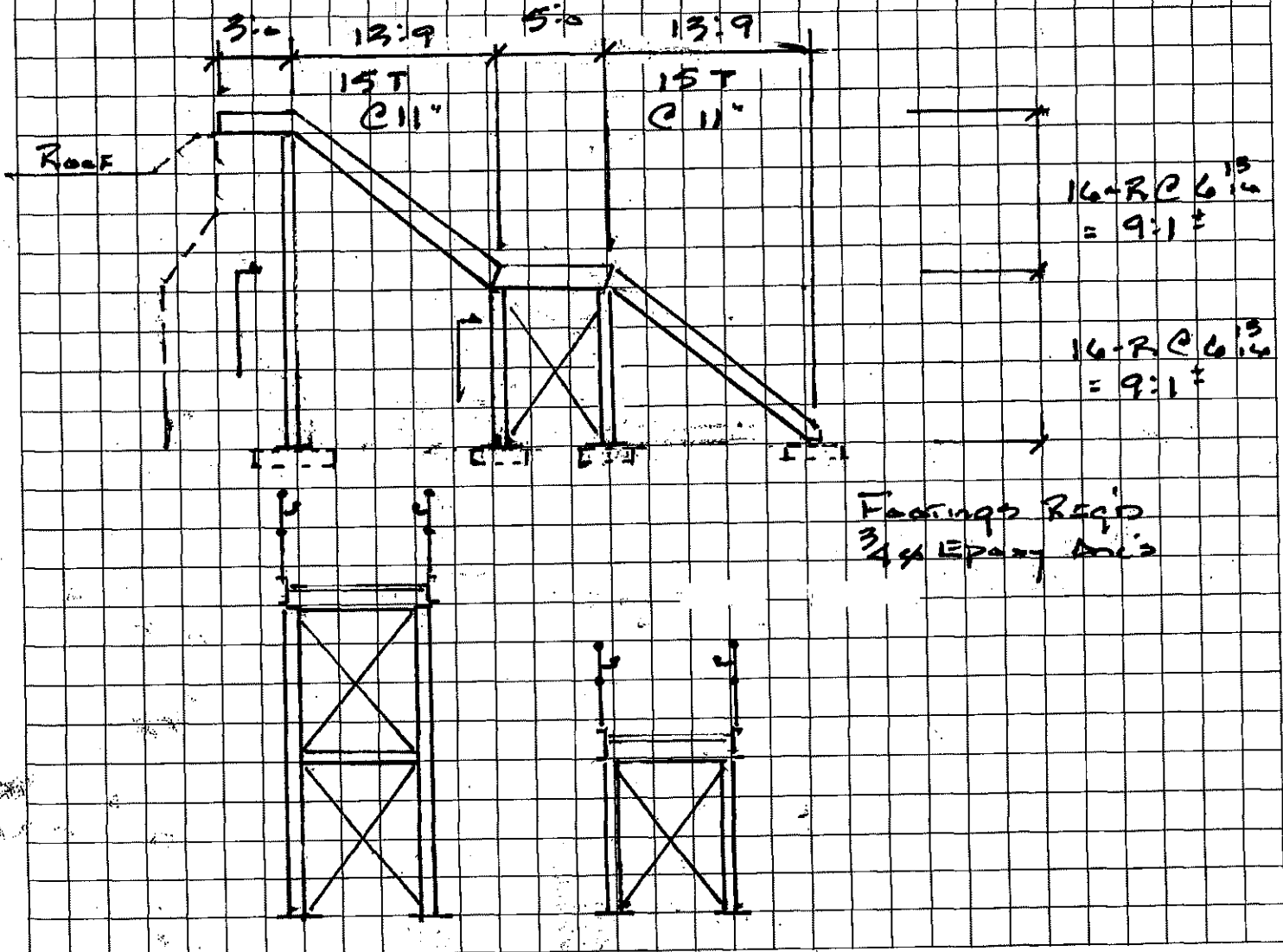



Jeffrey Brann <jbrann@nucps.net>

Fwd: Roof stairs

1 message

Stanley Langford <Stanley@connemaracorp.com>
To: jbrann <jbrann@nucps.net>
Cc: Connemara <connemara@connemaracorp.com>

Thu, Oct 12, 2023 at 10:14 AM

Sent from my iPhone

Begin forwarded message:

From: Connemara <connemara@connemaracorp.com>
Date: October 2, 2023 at 1:19:24 PM EDT
To: jbrann@nucps.net, hwargo@nucps.net
Cc: Connemara <connemara@connemaracorp.com>
Subject: Roof stairs

Jeff,

Please see updated pricing for the exterior roof stairway.

Permit

Porta potty

Clean up

Galvanized stair per previous drawing

Concrete footer

Supervision

Total \$67,140

10/12/23, 10:15 AM

Northumberland County Public Schools Mail - Fwd: Roof stairs

Thank you

Stanley

Stanley Langford

Connemara Corporation

804 435 1551 Office

804 445-5341 Cell

connemara@connemaracorp.com

Northumberland County Draft Capital Improvement Program Project Form

<p>(1) Office/Department : NCPS Maintenance Department</p>	
<p>(2) Project Title Urgent Necessary Desirable</p> <p style="text-align: center;">Project Priority: Urgent Year Required: 2024</p>	
<p>(3) Project Description (include sketches, appraisals, plans, etc.) NCPS Athletic Track Resurfacing</p> <p>Attachment #</p>	
<p>(4) Project Justification (includes ramifications if project is not implemented) The current athletic track surface is showing signs of wear from continual usage and is also starting to delaminate from its concrete undersurface. The maintenance department continually patches damaged areas to prevent any trip hazards, however, the affected areas are gradually getting larger and more difficult to repair. Also, the painted lane stripes are becoming less visible due to continued used and u/v damage.</p> <p>Attachment # <u>Northumberland Budget 2023-Revised.pdf</u></p>	
<p>(5) Cost (include staffing needs, annual O&M requirements, planning/engineering, equipment/furniture, acquisition, construction) \$292,540</p>	
<p>(6) Funding Source(s)</p> <p>Current Revenue Grant (Type) Revenue Bond Loan (Type) General Obligation Bond Special Assessment Capital Reserve Fund Other</p>	

Requestor Date

Planning Commission Meeting

Date/Time

Planning Commission Comments:

PRECISION ATHLETICS INC.

804-585-8015 (P/F)

P.O. BOX 8500 RICHMOND VA 23226-9998

www.prec-ath.com; email info@prec-ath.com

November 10, 2023

VIA EMAIL

To: Jeffrey Brann, Northumberland Public Schools

RE: Northumberland HS Running Track Renovations

We are pleased to submit the following budget pricing for the renovations to the existing running track facilities located at Northumberland HS.

Proposed scope of work at the facility:

NORTHUMBERLAND HS

Condition-the running track is in poor condition. No work has been completed since the track was originally installed (same Maxflex surfacing we are pricing). There is significant wear apparent in all areas of the existing rubberized surfacing. There are many areas where the original track surfacing is worn away. The lines have faded and the surfacing is beginning to oxidize significantly from being exposed to outdoor elements (will begin to wear faster). The line markings/paint on the running track/runways have faded from use and there is more wear to these areas.

Proposed scope-remove existing rubberized surfacing. Mill asphalt and repave track as described below. Oversee asphalt placement. Install new Maxflex BL 3/8" surfacing and paint lines. Install new field event equipment as required.

Projected Scope/Cost:

Remove rubber surface
Mill asphalt are required
Install 1 1/2" of asphalt
Provide engineering, layout as required
Install Maxflex BL 3/8"

Track and event markings-8-lane
Long jump markings
Long jump take-off boards (4)

Total Cost \$292,540

Paving scope of work will provide engineered mill of asphalt base approximately 3' from interior edge of track to avoid drain. The mill will be tapered as we work to outer edge of track and the mill will zero out to increase cross slope.

We anticipate that completing the entire scope of work will require 7-9 weeks. Based on current geopolitical events and supply chain constraints, there may be delays in obtaining certain materials required to complete the project within the 6-8 week timeframe.

Any existing asphalt or stone base that is found to be unsuitable will be repaired at agreed upon unit prices. Milling/Paving operations utilize heavy equipment that could cause the existing asphalt or stone base to fail. Any required repairs will be an added cost to the pricing provided in this quotation. We also assume that a tapered milling scope of work will be possible to achieve with the condition of the existing asphalt base. If we are not able to complete a tapered mill, we may need to change the milling plan which may involve a change in scope of work and possibly project cost.

Excluded are any required utility adjustments or irrigation system adjustments. Owner is to provide space for storage of materials and access to the facility for our equipment during the completion of the project.

Please contact me should you need any additional information or have any questions.

Sincerely,

Northumberland County Draft Capital Improvement Program Project Form

<p>(1) Office/Department: NCPS Maintenance Department</p>	
<p>(2) Project Title Urgent Necessary Desirable:</p> <p style="text-align: center;">Project Priority: Urgent (Health & Safety) Year Required: 2024</p>	
<p>(3) Project Description (include sketches, appraisals, plans, etc.) The current NES interior flooring consists of carpeting and vinyl composite tile that has been in place for 26 years. The vinyl composite tile(vct) shows severe wear and requires constant stripping and waxing. The NES kindergarten and first grade pods underwent a complete floor replacement last summer that consisted of the removal of all carpet and vct, replacing it with an Luxury Vinyl Tile(LVT) flooring that requires no stripping or waxing. The LVT was installed in these spaces as a test of its durability and wear. To date this flooring has proven to be resilient, easy to clean, and easy to replace due to its 1'x2' glue down tile design. The maintenance department recommends proceeding with the installation of LVT throughout the rest of the facility with the exception of the library, which will need carpet due to its sound deadening capabilities. The remaining locations consist of the 2nd grade, 3rd grade, 4th grade, and 5th grade pods along with all hallways and the cafeteria.</p> <p>Attachment # NES Flooring Renovation Budget Quotation.pdf</p>	
<p>(4) Project Justification (includes ramifications if project is not implemented) The current NES interior flooring consists of carpeting and vinyl composite tile that has been in place for 26 years. The carpeting has far surpassed its service life and has become a safety concern. The vinyl composite tile(vct) shows severe wear and requires constant stripping and waxing. Stripping and waxing floors is not a cost effective option for floor maintenance as it requires extensive labor hours to complete, the materials needed are very expensive, and the stripper required to remove old wax from these floors is harmful to the people using it as well as the school's sewage system. Due to the hazardous chemical makeup of the stripper an outside source has to be utilized such as Safety Clean to remove it from school grounds. The new LVT flooring system that was installed in the kindergarten and 1st grade pod needs no stripping and waxing, can be cleaned with any neutral base floor cleaner, and is cheap to repair due to its glue down install feature.</p> <p>Attachment #</p>	
<p>(5) Cost (include staffing needs, annual O&M requirements, planning/engineering, equipment/furniture, acquisition, construction)The total cost to replace the existing flooring with the LVT in the Kindergarten and 1st grade pods was \$94,845.00. This included 12 classrooms and the center break-out areas for each pod(2 total). The cost to complete the rest of the facility would be \$492,687.00. This cost is based on the remaining sq. footage and the exact cost for the square footage of the two pods already completed.</p>	

(6) Funding Source(s)

Current Revenue Grant (Type)

Revenue Bond Loan (Type)

General Obligation Bond Special Assessment

Capital Reserve Fund Other

Requestor Date

Planning Commission Meeting

Date/Time

Planning Commission Comments:



HODGMAN'S

Quotation

May 4, 2022

Northumberland County Public Schools
6958 Northumberland Highway
Heathsville, VA 22473

Attn: Jeffrey Brann

Re: Northumberland Elementary School – Kindergarten + First Grade Flooring Renovation

Dear Mr. Brann,

We are pleased to submit a quotation on the above referenced project per our site visit on April 28, 2022 and plans Dated: May 15, 1994.

Our quotation is based on the following:

1. Removal of the existing VCT and carpet in classrooms, restrooms and commons.
2. Provide and install Mannington 12" x 24" Primary Elements LVT (Color: TBD) and Roppe 4 1/2" vinyl cove base (Color: TBD) in classrooms and commons.
3. Provide and install Mannington Biospec MD sheet vinyl (Color: TBD) in Classroom Restrooms.
4. Pricing is based on normal working hours.
5. Northumberland County Public Schools is responsible for moving all furniture, equipment and toilets prior to Hodgman's arrival.
6. Skim coating of floor is included at all areas receiving LVT and sheet vinyl.

Pricing:

Kindergarten Pod Only (Excludes Resource Room) - **\$47,322.00**

Add On of Resource Room - **\$2,669.00**

Kindergarten + First Grade Pod (Includes both Resource Rooms) – **\$94,845.00**

Inclusions: Skim Coat; Minor floor prep; minor scraping; light sweeping; patching small holes/cracks.

Exclusions: Major floor preparation; scrape paint; patch large holes/cracks; grinding; leveling; moisture mitigation; final clean/waxing of any flooring or substrate; protection of installed flooring; moving furniture and/or equipment; off-hours labor, special adhesives for high moisture conditions; wall prep; vertical transportation. Hodgman's must be supplied with temporary heat or electricity. NOTE: All patterns qualified in specifications, but not on plans will be figured as full tile patterns with no off-site cutting required. This includes all special patterns.



HODGMAN'S

Our quotation is **SEE ABOVE:** Materials, adhesives, freight, labor and applicable tax are included. Materials will be billed when received in our warehouse with labor being billed as the job progresses. Our terms are: Cash Net 15 Days from the invoice date; payments by credit, debit or purchasing cards shall authorize us to collect a surcharge of 2% of the invoiced amount. American Express is not accepted.

If you have any questions or comments, please call.

Sincerely,

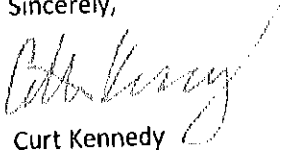
Curt Kennedy

ACCEPTED BY: _____ DATE: _____
NOTE: Quotation must be reconfirmed if not accepted within 15 days

Northumberland Elementary School

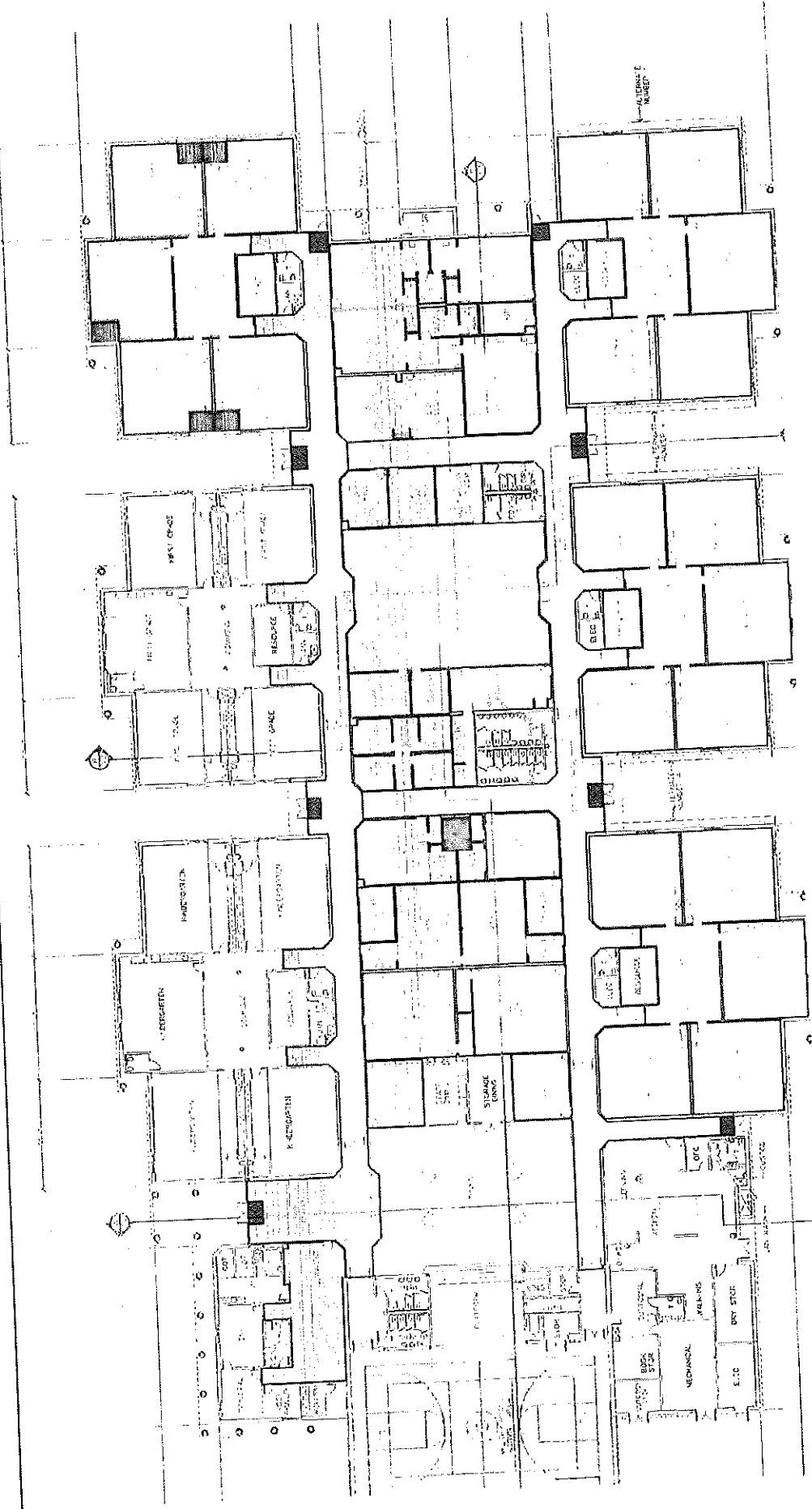

- [LVT-1] Mannington Primary Elements 12" x 24" LVT: Crystal
- [LVT-2] Mannington Primary Elements 12" x 24" : Green
- [SV] Mannington Biospec MD Sheet Vinyl: TBD
- AB Texas Granite 12" x 12" Tiles: TBD
- Fordom Walk Off Justice Carpet Tile 20" x 20": tbd
- Mannington Blueprint 24" x 24" Carpet Tile: TBD



HODGMAN'S

Budget Quotation

November 10, 2023

Northumberland County Public Schools
6958 Northumberland Highway
Heathsville, VA 22473

Attn: Jeffrey Brann

Re: Northumberland Elementary School – Kindergarten + First Grade Flooring Renovation

Dear Mr. Brann,

We are pleased to submit a quotation on the above referenced project per our site visit on April 28, 2022 and plans Dated: May 15, 1994.

Our quotation is based on the following:

1. Removal of the existing VCT and carpet in classrooms, restrooms and commons.
2. Removal of existing VCT in main hallways and offices/classrooms in middle of school, per the attached mock up.
3. Provide and install Mannington 12" x 24" Primary Elements LVT (Color: Crystal) with Random Pattern LVT (Color: Verdant) and Roppe 4 1/2" vinyl cove base (Color: Forest Green) in classrooms and commons.
4. Provide and install Mannington Biospec MD sheet vinyl (Color: New Glacier) in Classroom Restrooms.
5. Provide and install American Biltrite Texas Granite 12" x 12" Vinyl Tile (Color: TBD) in all hallway areas and offices/classrooms, per the attached mockup.
6. Provide and install Mannington Quick Ship Carpet Tile, Color: TBD, in Library and Librarian Office.
7. Provide and install Fordam Walk Off Carpet Tile in all entry ways.
8. Pricing is based on normal working hours.
9. Northumberland County Public Schools is responsible for moving all furniture, equipment and toilets prior to Hodgman's arrival.
10. Skim coating of floor is included at all areas receiving LVT, Vinyl Tile and sheet vinyl.



HODGMAN'S

Inclusions: Skim Coat; Minor floor prep; minor scraping; light sweeping; patching small holes/cracks.

Exclusions: Major floor preparation; scrape paint; patch large holes/cracks; grinding; leveling; moisture mitigation; final clean/waxing of any flooring or substrate; protection of installed flooring; moving furniture and/or equipment; off-hours labor, special adhesives for high moisture conditions; wall prep; vertical transportation. Hodgman's must be supplied with temporary heat or electricity. NOTE: All patterns qualified in specifications, but not on plans will be figured as full tile patterns with no off-site cutting required. This includes all special patterns.

Our Budget quotation is **\$492,687.00**. Materials, adhesives, freight, labor and applicable tax are included. Materials will be billed when received in our warehouse with labor being billed as the job progresses. Our terms are: Cash Net 15 Days from the invoice date; payments by credit, debit or purchasing cards shall authorize us to collect a surcharge of 2% of the invoiced amount. American Express is not accepted.

If you have any questions or comments, please call.

Sincerely,

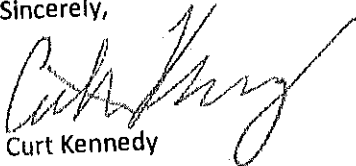

Curt Kennedy

ACCEPTED BY: _____

DATE: _____

NOTE: Quotation must be reconfirmed if not accepted within 15 days

Northumberland County Draft Capital Improvement Program Project Form

<p>(1) Office/Department NCPS MAINTENANCE DEPARTMENT</p>	
<p>(2) Project Title Urgent Necessary Desirable</p> <p style="text-align: center;">Project Priority URGENT Year Required</p>	
<p>(3) Project Description (include sketches, appraisals, plans, etc.) Replace the existing 28 year old 125KW generator system with a new 125 KW generator system.</p> <p>Attachment #</p>	
<p>(4) Project Justification (includes ramifications if project is not implemented) The current generator onsite at NE5 is nearing the end of its service life due to high operating hours and excessive annual costs to maintain. Due to the sensitivity of all electronic equipment, to include computers, data networks, rooftop climate control units, etc, it is essential to replace the existing generator with a more modern system that will provide the precise power supply needed to keep these systems running. The new generator is a 125KW GENSET that is able to properly maintain all emergency circuits.</p> <p>Attachment # <u>SOURCEWELL - D125GC Cat Diesel Genset for Northumberland County Schools, 480v, L2SA, 24hr Tank-RPS.pdf</u></p>	
<p>(5) Cost (include staffing needs, annual O&M requirements, planning/engineering, equipment/furniture, acquisition, construction) \$46,239.28</p>	
<p>(6) Funding Source(s)</p> <p>Current Revenue Grant (Type) Revenue Bond Loan (Type) General Obligation Bond Special Assessment Capital Reserve Fund Other</p>	

Requestor Date

Planning Commission Meeting

Date/Time

Planning Commission Comments:



10/31/2023

Quote#: GBO099898-RPS

NORTHUMBERLAND PUBLIC SCHOOLS via SOURCEWELL Contract 092222-CAT**USING SOURCEWELL CONTRACT PRICING**

One (1) Caterpillar Diesel Fueled Packaged Generator Set Model D125GC with Brushless Generator, 125 kW Standby at 0.8 P.F., 277/480 Volt, 3-Phase, 60 Hertz at 1800 RPM.

SOURCEWELL CONTRACT ITEMS**BASE MODEL**

- EPA STATIONARY EMERGENCY CERTIFIED- EPA TIER 3 & CARB EMISSIONS LEVELS (PER EPA NSPS RULE)
 - NAC308P [D125GC, 125kW, 277/480V, 60Hz ENGINE-GENERATOR SET – 3-PHASE]

ATTACHMENTS

- **EMISSION CERTIFICATION**
 - CERTESE [STATIONARY EMERGENCY]
- **UL LISTING**
 - ULLIST – [UL2200 LISTED PACKAGE]
- **VOLTAGE INDICATOR**
 - 60H0480 [277/480V 3-PHASE]
- **APPLICATION INDICATOR**
 - STANDBY [STANDBY RATING]
- **CONTROL PANEL**
 - GCCP1 [GCCP1 AUTOSTART CONTROL PANEL]
 - FSS [FUEL LEVEL ALARMS]
 - GFCICS1 [20a GFCI OUTLET INSTALLED]
 - EMCCAS5 [VOLT FREE ALARM CONTACTS and GEN RUN RELAY]
 - PAA1 [LOCAL ALARM HORN WITH MUTE]
- **GENERATOR and GENERATOR ATTACHMENTS**
 - OGNSEKC [CAT 60HZ GENERATOR- M2256L4 105 DEGREE]
 - PMEXCI3 [PERMANENT MAGNET EXCITATION]
 - AH1H – [GENERATOR ANTI-CONDENSATION HEATER]
- **CIRCUIT BREAKERS (2 Total)**
 - CB0252A [250A/3P/100% RATED, ADJUSTABLE TRIP]
 - CB0253A [250A/3P/100% RATED, ADJUSTABLE TRIP]
 - SHTAUX – [Shunt Trip and Aux Contacts]
 - SUSE – [Suitable for Service Entrance Labeled and Oversized NEUTRAL BAR INSTALLED]
- **COOLING SYSTEM**
 - WSS1 [LOW COOLANT LEVEL SHUTDOWN CIRCUIT]
 - WCA1 [LOW COOLANT LEVEL ALARM 69/80 degree F]
 - WHH2 [COOLANT WATER HEATER, 90/130 degree F]
 - CWRESV [COOLANT RESERVOIR]
- **ENCLOSURE**
 - ENCSAB3 [Level 2 SOUND ATTENUATED WEATHERPROOF ENCLOSURE WITH INTERNAL SILENCER – 75.4 dBA @ 23' UNDER FULL LOAD] [CATERPILLAR WHITE in COLOR]

NORTHUMBERLAND PUBLIC SCHOOLS via SOURCEWELL Contract 092222-CAT

- **FUEL STORAGE SYSTEM**
 - FTDW045 - [400-Gallon INTEGRAL-142 Double-Wall, 36-HR Runtime @ 100% Load, 45hr at 75%, and 62hr at 50%, FUEL TANK]
 - FFLCK - [LOCKING FUEL CAP]
 - FLEKP - [LEAK PROBE]
 - FAHL90 - [HIGH FUEL ALARM / 90%]
- **STARTING/CHARGING SYSTEM**
 - BTC1028 [BATTERY CHARGER 10A, NFPA 110 Compliant]
 - BAT2465 [12v LEAD ACID BATTERY SYSTEM with RACK]
- **TESTS/REPORTS**
 - STDTEST [Factory 0.8 POWER FACTOR TEST]
- **OTHER**
 - ANNR02 - ONE (1) GENERATOR 16-Light REMOTE ANNUNCIATOR (Ships Loose)
 - EMGSTP - ONE (1) GENERATOR EMERGENCY STOP (Ships Loose)
 - PL444 - CAT PRODUCT LINK LTE TELEMATICS INSTALLED

BASE MODEL & ATTACHMENT LIST PRICE..... \$ 48,350.00

SOURCEWELL MEMBER DISCOUNT (31%)(-) \$ 15,089.87

TOTAL SOURCEWELL MEMBER GENERATOR ONLY CONTRACT PRICE: \$ 33,361.50

OTHER SOURCEWELL DISCOUNTABLE PRICE ITEMS

- FIVE (5) YEAR/2500HR PLATINUM LEVEL EXTENDED GENSET WARRANTY, NO DEDUCTIBLES
- ALL INCOMING/OUTGOING FREIGHT AND JOBSITE DELIVERY
- NECESSARY YARDWORK
- STANDARD STARTUP SERVICE DURING OUR NORMAL WORKING HOURS (NO FUEL INCLUDED)
 - INCLUDES ANY MILEAGE AND TRAVEL CHARGES
- TWO (2) HOUR RESISTIVE LOADBANK TESTING AT TIME OF STARTUP DURING OUR NORMAL WORKING HOURS
 - NO FUEL INCLUDED.
- ONSITE OWNER PERSONNEL TRAINING SESSION DURING STARTUP & TESTING
- ONE (1) 230 AMP AUTOMATIC TRANSFER SWITCH, NON-SERVICE ENTRANCE RATED
 - NEMA-1 INDOOR ENCLOSURE, 3-POLE, OPEN TRANSITION, ENGINE EXERCISER PACKAGE.
 - TWO (2) YEAR ATS WARRANTY STARTS WHEN IT SHIPS FROM THE ATS FACTORY.

• **OTHER SOURCEWELL DISCOUNTABLE NET PRICE ITEMS.....(+) \$ 12,877.78**

DIESEL GENERATOR PRICE + OTHER ITEMS PRICING =

<p>TOTAL <u>CUSTOMER NET</u> PRICE, F.O.B. Jobsite:..... \$ 46,239.28*</p> <p style="text-align: center;">SOURCEWELL Contract # 092222-CAT</p> <p style="text-align: center;"><small>*Does not include any applicable taxes</small></p>

10/31/2023

NORTHUMBERLAND PUBLIC SCHOOLS via SOURCEWELL Contract 092222-CAT

RELATED ITEMS NOT INCLUDED:

- Customer is responsible for off-loading (crane rental) equipment onsite.
- Customer is responsible for installation of all equipment.
- Customer is responsible for all Diesel Fuel needs.

NOTES AND COMMENTS:

- The content of this proposal is intended solely for the use of Sourcewell members and may contain privileged information which should be treated as confidential.
- This proposal is based on the information provided by the end user; no project plans or specifications have been referenced.
- This proposal is based on utilizing SOURCEWELL Contract #092222-CAT. SOURCEWELL's contract number must be referenced on the purchase order.
- APPROXIMATE DIMENSIONS of Genset: 158" L x 52" W x 75"H and weighs 4,500lbs.

TERMS:

- Net Thirty Days with Approved Credit
- Quotation is Valid for Thirty (30) Days from date of Proposal.
- Due to significant increases in material costs for items such as copper, brass, aluminum, and steel, Carter Machinery reserves the right to pass on price increases in the form of a materials surcharge. If Carter Machinery's cost increases between the date of this quotation and the release of the product for production, Carter Machinery may add a materials surcharge to cover the increase. Such materials surcharge will carry the same terms and conditions as the other elements of this quotation and the invoicing therein.

FACTORY LEAD TIMES:

- Generator Set: In Stock on Carter Machinery lot. Can be held with PO only and is subject to prior sale.
- Automatic Transfer Switch: around 5 weeks after approval and release to order.

CARTER MACHINERY CO., INC.

By: Gary Ouellette
Gary Ouellette – Power Systems Sales Representative

Craig A. Brander
Craig A. Brander – Power Systems Sales Engineer

Thank you for the Opportunity!



LET'S GET TO WORK.

Carter Machinery Company, Inc.
10990 Air Park Road, Ashland, VA 23005

Gary Ouellette Phone: (804) 823-1163 * Craig Brander Phone: (804) 380-3649

Quote#: CAB30971309-R1

2/1/2023

NORTHUMBERLAND PUBLIC SCHOOLS via SOURCEWELL Contract 092222-CAT

USING SOURCEWELL CONTRACT PRICING

One (1) Caterpillar Diesel Fueled Packaged Generator Set Model D125GC with Brushless Generator, 125 kW Standby at 0.8 P.F., 277/480 Volt, 3-Phase, 60 Hertz at 1800 RPM.

SOURCEWELL CONTRACT ITEMS

BASE MODEL

- EPA STATIONARY EMERGENCY CERTIFIED- EPA TIER 3 & CARB EMISSIONS LEVELS (PER EPA NSPS RULE)
 - NAC308P [D125GC, 150kW, 277/480V, 60Hz ENGINE-GENERATOR SET – 3-PHASE]

ATTACHMENTS

- EMISSION CERTIFICATION
 - CERTESE [STATIONARY EMERGENCY]
- UL LISTING
 - ULLIST – [UL2200 LISTED PACKAGE]
- VOLTAGE INDICATOR
 - 60H0480 [277/480V 3-PHASE]
- APPLICATION INDICATOR
 - STANDBY [STANDBY RATING]
- CONTROL PANEL
 - GCCP1 [GCCP1 AUTOSTART CONTROL PANEL]
 - FSS [FUEL LEVEL ALARMS]
 - GFCICS1 [20a GFCI OUTLET INSTALLED]
 - EMCCAS5 [VOLT FREE ALARM CONTACTS and GEN RUN RELAY]
 - PAA1 [LOCAL ALARM HORN WITH MUTE]
- GENERATOR and GENERATOR ATTACHMENTS
 - OGNSEKC [CAT 60HZ GENERATOR- M2256L4 105 DEGREE]
 - PMEXCI3 [PERMANENT MAGNET EXCITATION]
 - AHIH – [GENERATOR ANTI-CONDENSATION HEATER]
- CIRCUIT BREAKERS (2 Total)
 - CB0252A [250A/3P/100% RATED, ADJUSTABLE TRIP]
 - CB0253A [250A/3P/100% RATED, ADJUSTABLE TRIP]
 - SHTAUX – [Shunt Trip and Aux Contacts]
 - SUSE – [Suitable for Service Entrance Labeled and Oversized NUTRAL BAR INSTALLED]
- COOLING SYSTEM
 - WSS1 [LOW COOLANT LEVEL SHUTDOWN CIRCUIT]
 - WCA1 [LOW COOLANT LEVEL ALARM 69/80 degree F]
 - WHH2 [COOLANT WATER HEATER, 90/130 degree F]
 - CWRESV [COOLANT RESERVOIR]
- ENCLOSURE
 - ENCSAB3 [Level 2 SOUND ATTENUATED WEATHERPROOF ENCLOSURE WITH INTERNAL SILENCER – 75.4 dBA @ 23' UNDER FULL LOAD] [CATERPILLAR WHITE in COLOR]

NORTHUMBERLAND PUBLIC SCHOOLS via SOURCEWELL Contract 092222-CAT

- **FUEL STORAGE SYSTEM**
 - FTDW045 - [400-Gallon INTEGRAL-142 Double-Wall, 36-HR Runtime @ 100% Load, 45hr at 75%, and 62hr at 50%, FUEL TANK]
 - FFLCK - [LOCKING FUEL CAP]
 - FLEKP - [LEAK PROBE]
 - FAHL90 - [HIGH FUEL ALARM / 90%]
- **STARTING/CHARGING SYSTEM**
 - BTC1028 [BATTERY CHARGER 10A, NFPA 110 Compliant]
 - BAT2465 [12v LEAD ACID BATTERY SYSTEM with RACK]
- **TESTS/REPORTS**
 - STDTEST [Factory 0.8 POWER FACTOR TEST]
- **OTHER**
 - ANNR02 - ONE (1) GENERATOR 16-Light REMOTE ANNUNCIATOR (Ships Loose)
 - EMGSTP - ONE (1) GENERATOR EMERGENCY STOP (Ships Loose)
 - PL444 - CAT PRODUCT LINK LTE TELEMATICS INSTALLED

BASE MODEL & ATTACHMENT LIST PRICE:..... \$ 48,677.00

SOURCEWELL MEMBER DISCOUNT (31%):.....(-) \$ 15,089.87

TOTAL SOURCEWELL MEMBER GENERATOR ONLY CONTRACT PRICE: \$ 33,587.13

OTHER SOURCEWELL DISCOUNTABLE PRICE ITEMS

- FIVE (5) YEAR/2500HR PLATINUM LEVEL EXTENDED GENSET WARRANTY, NO DEDUCTIBLES
- ALL INCOMING/OUTGOING FREIGHT AND JOBSITE DELIVERY
- STANDARD STARTUP SERVICE DURING OUR NORMAL WORKING HOURS
 - INCLUDES ANY MILEAGE AND TRAVEL CHARGES
- TWO (2) HOUR RESISTIVE LOADBANK TESTING at Time of Startup during our Normal Working Hours
 - No Fuel Included.
- ONSITE OWNER PERSONNEL TRAINING SESSION DURING STARTUP
- ONE (1) 230 Amp AUTOMATIC TRANSFER SWITCH, NON-Service Entrance Rated
 - Nema-1 Indoor Enclosure, 3-Pole, Open Transition, Engine Exerciser Package.

• **OTHER SOURCEWELL DISCOUNTABLE NET PRICE ITEMS:.....(+) \$ 12,761.05**

DIESEL GENERATOR PRICE + OTHER ITEMS PRICING =

TOTAL CUSTOMER NET PRICE, F.O.B. Jobsite:..... \$ 46,348.18

SOURCEWELL Contract # 092222-CAT

Does not include any applicable taxes

2/1/2023

NORTHUMBERLAND PUBLIC SCHOOLS via SOURCEWELL Contract 092222-CAT

RELATED ITEMS NOT INCLUDED:

- Customer is responsible for off-loading (crane rental) equipment onsite.
- Customer is responsible for installation of all equipment.
- Customer is responsible for all Diesel Fuel needs.

NOTES AND COMMENTS:

- The content of this proposal is intended solely for the use of Sourcewell members and may contain privileged information which should be treated as confidential.
- This proposal is based on the information provided by the end user; no project plans or specifications have been referenced.
- This proposal is based on utilizing SOURCEWELL Contract #092222-CAT. SOURCEWELL's contract number must be referenced on the purchase order.
- APPROXIMATE DIMENSIONS of Genset: 158" L x 52" W x 75"H and weighs 4,500lbs.

TERMS:

- Net Thirty Days with Approved Credit
- Quotation is Valid for (30) THIRTY DAY from date of Proposal

FACTORY LEAD TIMES:

- Generator Set: Due into Carter Machinery Inventory around end of April 2023. Can be held with PO only and is subject to prior sale.
- Automatic Transfer Switch: around 8-9 weeks after approval and release

TERMS:

Net 30 Days

Quote Valid for 30 Days

By: *Gary Ouellette*
 Gary Ouellette – Power Systems Sales Representative

Craig A. Brander
 Craig A. Brander – Power Systems Sales Engineer

Thank you for the Opportunity!

Northumberland County Draft Capital Improvement Program Project Form

<p>(1) Office/Department: NCPS Maintenance Department</p>	
<p>(2) Project Title Urgent Necessary Desirable</p> <p style="text-align: center;">Project Priority: Urgent (Health & Safety) Year Required: 2023</p>	
<p>(3) Project Description (include sketches, appraisals, plans, etc.) Request to remove the NES playground to the opposite end of the facility and convert the existing playground into an additional parking lot for both the school and the Little League Park. The new playground would need to consist of a padded playing surface that would eliminate the need for annual mulching or rock dispersal.</p>	
<p>Attachment #</p> <p>(4) Project Justification (includes ramifications if project is not implemented) The current playground poses a severe safety risk for all elementary school students as this area is clearly visible from the road, giving an individual with bad intentions the opportunity to endanger anyone onsite. This site has also suffered greatly over the years from poor drainage. With the existing poor drainage issue heavy rains have made this playground unusable for multiple days at a time. The location of the current playground also prevents adequate parking for all Little League events. During the Little League season participants use the NES bus loop and parking lot for overflow parking. Converting the existing playground into an additional parking lot will alleviate this as well as provide increased handicap accessibility which both facilities have a strong need for.</p>	
<p>Attachment #</p> <p>(5) Cost (include staffing needs, annual O&M requirements, planning/engineering, equipment/furniture, acquisition, construction) \$500,000</p>	
<p>(6) Funding Source(s)</p> <p>Current Revenue Grant (Type) Revenue Bond Loan (Type) General Obligation Bond Special Assessment Capital Reserve Fund Other</p>	

Requestor Date

Planning Commission Meeting

Date/Time

Planning Commission Comments:

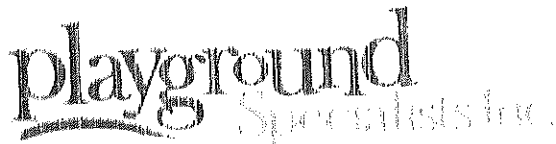

Playground Specialists Inc
 29 Apples Church Road
 Thurmont, MD 21788
 (800) 385-0075
 www.playspec.com

ADDRESS
 NORTHUMBERLAND
 ELEMENTARY SCHOOL
 ATTN: JEFFREY D. BRANN
 757 ACADEMIC LANE
 HEATHSVILLE, VA 22473

SHIP TO
 NORTHUMBERLAND ES
 C/O PLAYGROUND
 SPECIALISTS

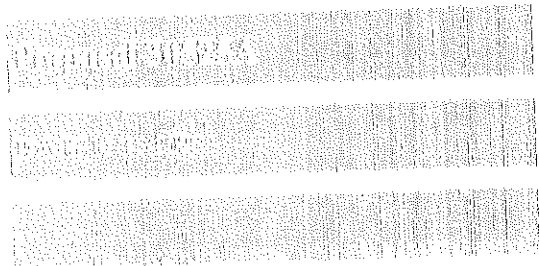

SALES REP
 JOE LATHAM



NOTE

HGAC CONTRACT #PR11-20

REMOVAL

REMOVE AND DISPOSE OF EXISTING PLAY
 EQUIPMENT IN PLAYGROUND FOOTPRINT. REMOVE
 APPROX 5" EXISTING MULCH AND DECOMPOSED
 MATERIALS TO PREP FOR NEW SURFACING AND
 DISPOSE OF IN EXISTING LOCATION ON SITE

PLAYWORLD EQUIPMENT

P111323-10A - CUSTOM PLAYGROUND DESIGN PER
 DRAWING

DISCOUNT

HGAC CONTRACT 10% DISCOUNT OFF PLAYWORLD
 LIST PRICE ABOVE

DISCOUNT

ADDITIONAL SPECIAL FACTORY DISCOUNT OFF LIST
 PRICE ABOVE

BERLINER PLAY EQUIPMENT

IKO M

DISCOUNT

HGAC CONTRACT 6% DISCOUNT OFF BERLINER LIST
 PRICE ABOVE

INSTALLATION

CERTIFIED INSTALLATION OF ALL EQUIPMENT
 ABOVE INCLUDING LIFETIME INSTALLATION
 WARRANTY

TIMBERS

INSTALL 206 LIN FT TWO TIER 4 X 6 TIMBERS - ON 3
 SIDES OF PLAY AREA

PLAYSPEC RAINBOW

INSTALL 5,404 SQ FT 2" PLAYSPEC RAINBOW BONDED
 RUBBER PLUS TWO (2) 1.5" PADS - TOP OF RUBBER TO
 BE FLUSH WITH EXISTING CURBING ALONG ASPHALT
 AND SLOPED DOWN TO MEET SIDEWALK ENTRY
 POINT

1	8,300.00	8,300.00
1	149,321.00	149,321.00
1	-14,932.10	-14,932.10
1	-7,465.00	-7,465.00
1	19,455.00	19,455.00
1	-1,167.30	-1,167.30
1	66,525.00	66,525.00
206	21.00	4,326.00
5,404	21.00	113,484.00



STONE

COMPACTED # 57 STONE FOR RUBBER BASE

1 28,161.00 28,161.00

RUBBER NOTE

CONTRACTOR NOT RESPONSIBLE FOR SECURITY AND VANDALISM DURING RUBBER INSTALLATION AND CURING TIME

- *Net 30 w/ PO
- *3% service charge for all credit card payments.
- *Pricing only guaranteed for 30 days unless specified above.
- *Absolutely no engineering, permits, permit fees, drainage, wage rates, bonding, or additional insurance included in above pricing unless specified on line item.
- *Additional mobilization, poor soils, limited access, or utility issues may result in change orders.
- *Standard lead times always apply. Contact sales agent for details.
- **Sign and return when approved. Thank you!

SUBTOTAL	366,007.60
TAX (0%)	0.00
SHIPPING	7,750.00



Accepted By

Accepted Date

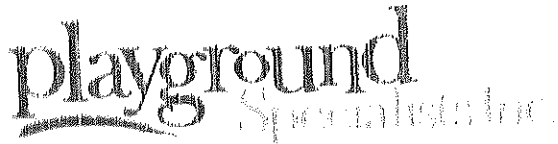

Playground Specialists Inc
 29 Apples Church Road
 Thurmont, MD 21788
 (800) 385-0075
 www.playspec.com

ADDRESS
 NORTHUMBERLAND
 ELEMENTARY SCHOOL
 ATTN: JEFFREY D. BRANN
 757 ACADEMIC LANE
 HEATHSVILLE, VA 22473

SHIP TO
 NORTHUMBERLAND ES
 C/O PLAYGROUND
 SPECIALISTS

SALES REP
 JOE LATHAM

NOTE

HGAC CONTRACT #PR11-20

REMOVAL

REMOVE AND DISPOSE OF EXISTING PLAY
 EQUIPMENT IN PLAYGROUND FOOTPRINT AND FILL
 HOLES - INCLUDES DUMPSTER CHARGES

PLAYWORLD EQUIPMENT

P111323-10A - CUSTOM PLAYGROUND DESIGN PER
 DRAWING

DISCOUNT

HGAC CONTRACT 10% DISCOUNT OFF PLAYWORLD
 LIST PRICE ABOVE

DISCOUNT

ADDITIONAL SPECIAL FACTORY DISCOUNT OFF LIST
 PRICE ABOVE

BERLINER PLAY EQUIPMENT

IKO M

DISCOUNT

HGAC CONTRACT 6% DISCOUNT OFF BERLINER LIST
 PRICE ABOVE

INSTALLATION

CERTIFIED INSTALLATION OF ALL EQUIPMENT
 ABOVE INCLUDING LIFETIME INSTALLATION
 WARRANTY

TIMBERS

INSTALL 324 LIN FT TWO TIER 4 X 6 TIMBERS

PLAYSPEC RAINBOW

INSTALL 5,515 SQ FT 2" PLAYSPEC RAINBOW BONDED
 RUBBER PLUS TWO (2) 1.5" PADS - INCLUDES POURED
 RAMP AT PLAYGROUND ENTRANCE

STONE

COMPACTED # 57 STONE FOR RUBBER BASE

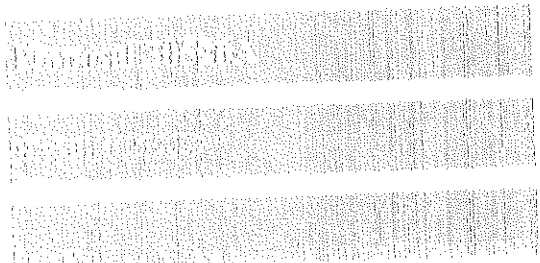

1	5,900.00	5,900.00
1	149,321.00	149,321.00
1	-14,932.10	-14,932.10
1	-7,465.00	-7,465.00
1	19,455.00	19,455.00
1	-1,167.30	-1,167.30
1	66,525.00	66,525.00
324	21.00	6,804.00
5,515	21.00	115,815.00
1	28,740.00	28,740.00

NOTE

AREA TO BE GRADED BY OTHERS AND READY FOR
NEW EQUIPMENT AND SURFACING PRIOR TO
INSTALLATION

RUBBER NOTE

CONTRACTOR NOT RESPONSIBLE FOR SECURITY AND
VANDALISM DURING RUBBER INSTALLATION AND
CURING TIME

*Net 30 w/ PO

*3% service charge for all credit card payments.

*Pricing only guaranteed for 30 days unless specified above.

*Absolutely no engineering, permits, permit fees, drainage, wage
rates, bonding, or additional insurance included in above pricing
unless specified on line item.

*Additional mobilization, poor soils, limited access, or utility
issues may result in change orders.

*Standard lead times always apply. Contact sales agent for
details.

**Sign and return when approved. Thank you!

SUBTOTAL	368,995.60
TAX (0%)	0.00
SHIPPING	7,750.00

Accepted By

Accepted Date

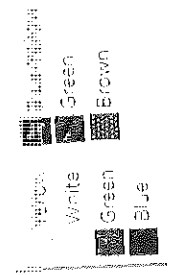
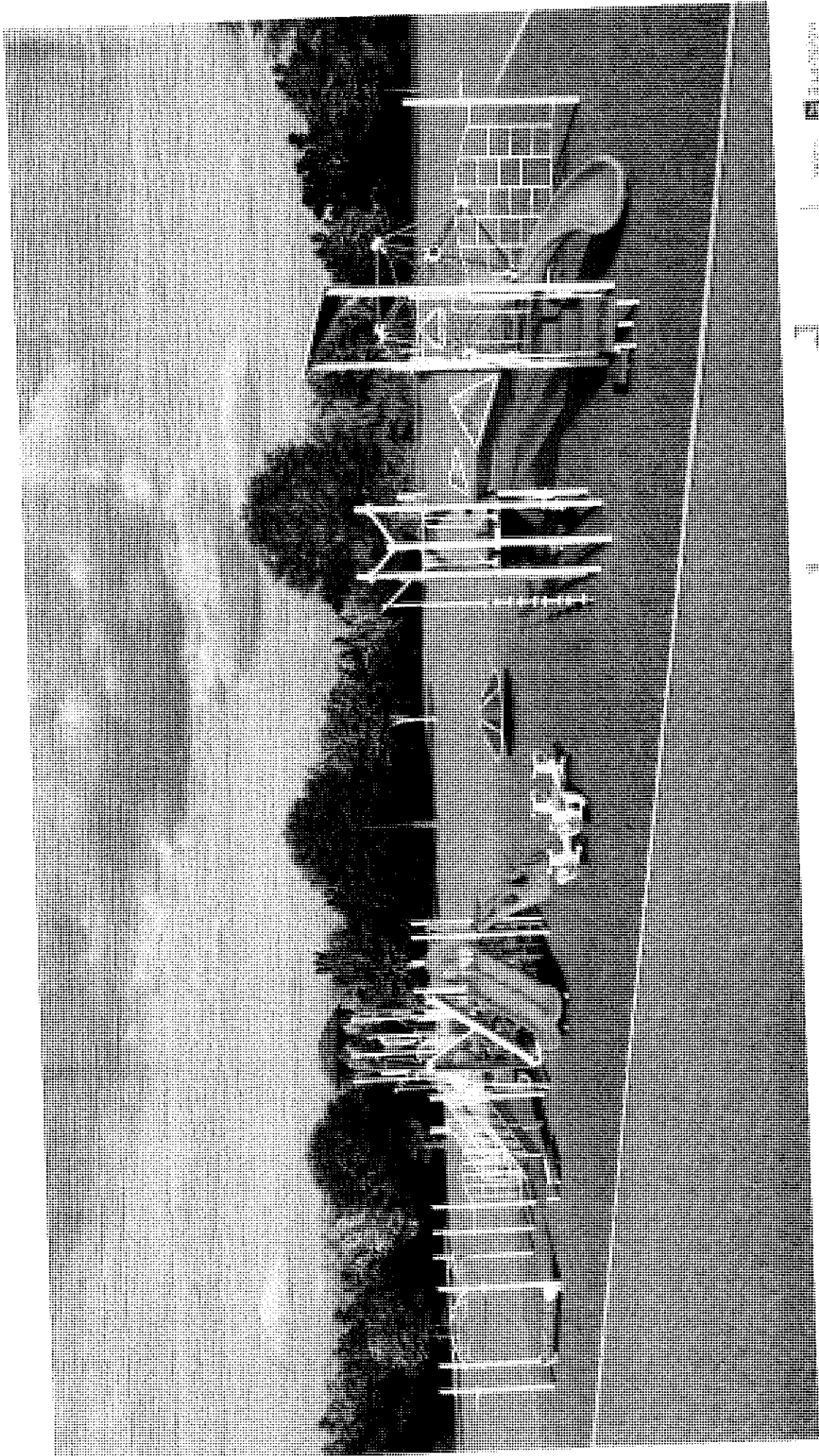

Northumberland Elementary School
playground
Specialists Inc.

800.385.5015 | www.playspec.com

Northumberland Elementary School
(New Area) - Hartsville, Virginia

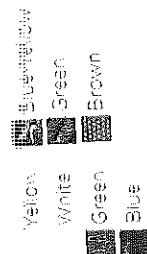
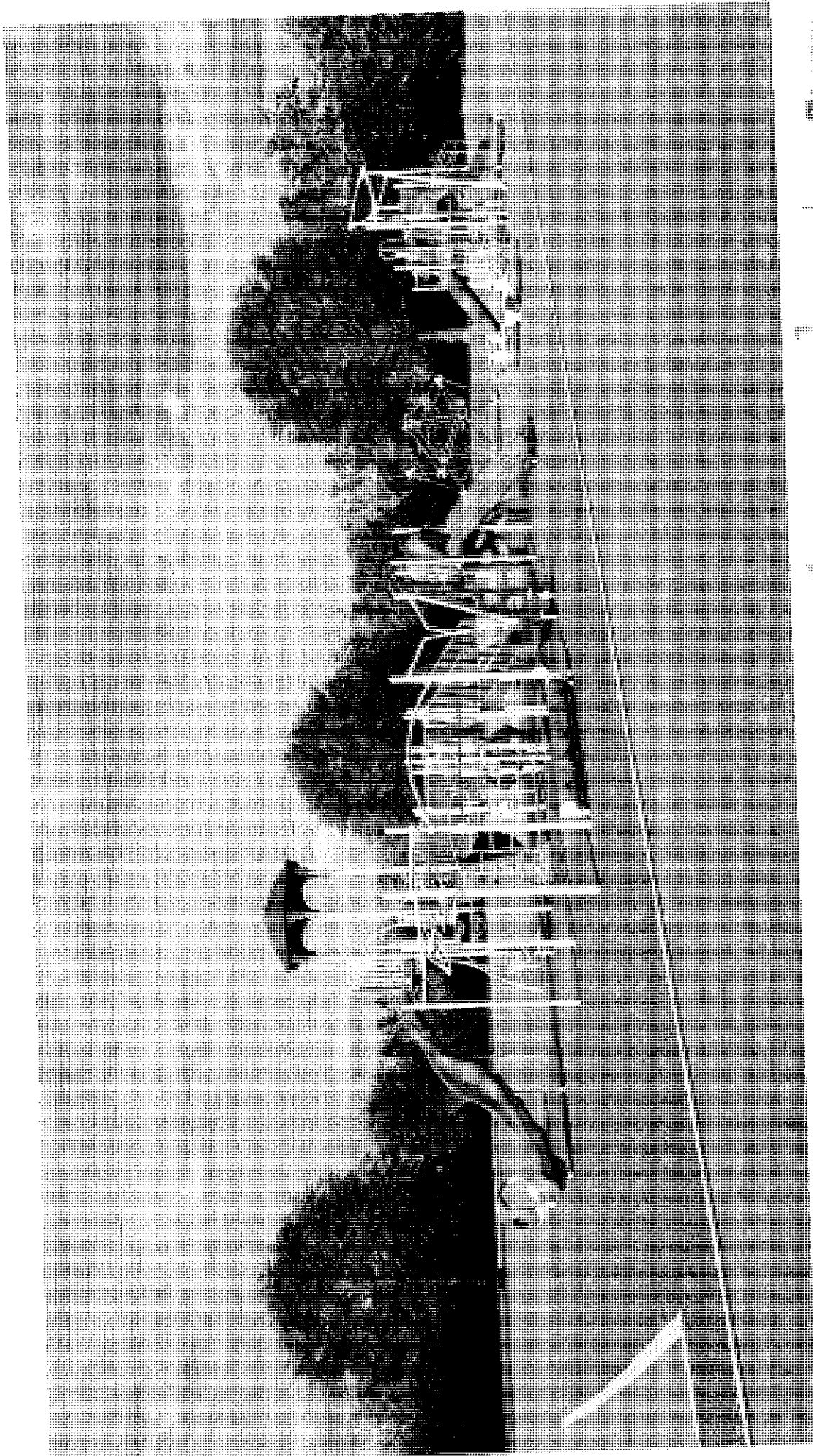

Northumberland Elementary School playground
Specialists, Inc.

800.886.0075 | www.playssci.com

(New Area) - Harrisville, Virginia

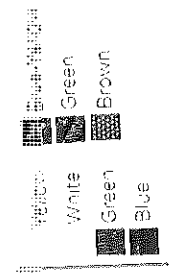
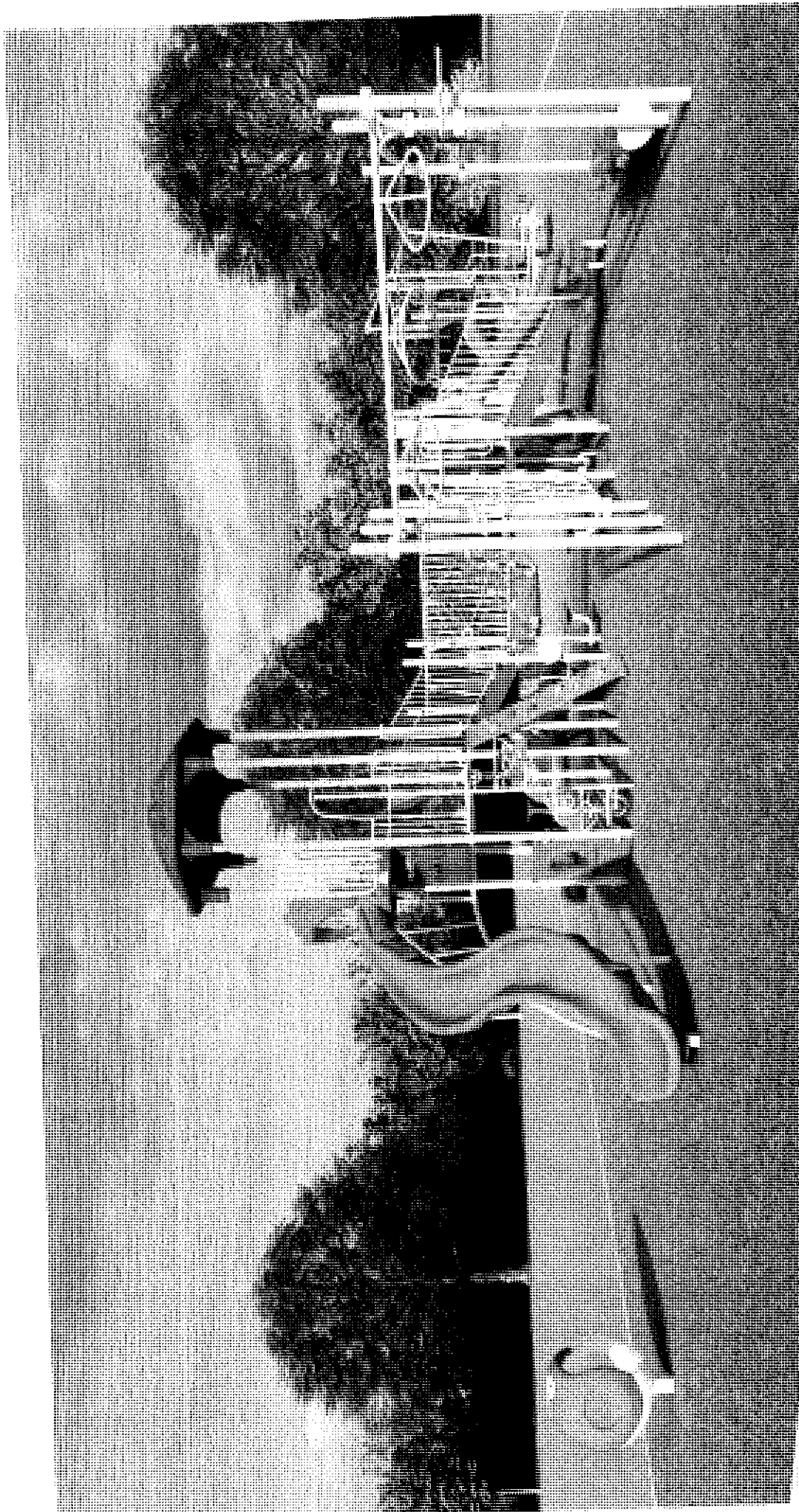

VEHICLE
White
Green
Blue

Northumberland Elementary School
(New Area) - Hartselle, Virginia

900.885.0075 | www.craysec.com

playground
Specialists, Inc.

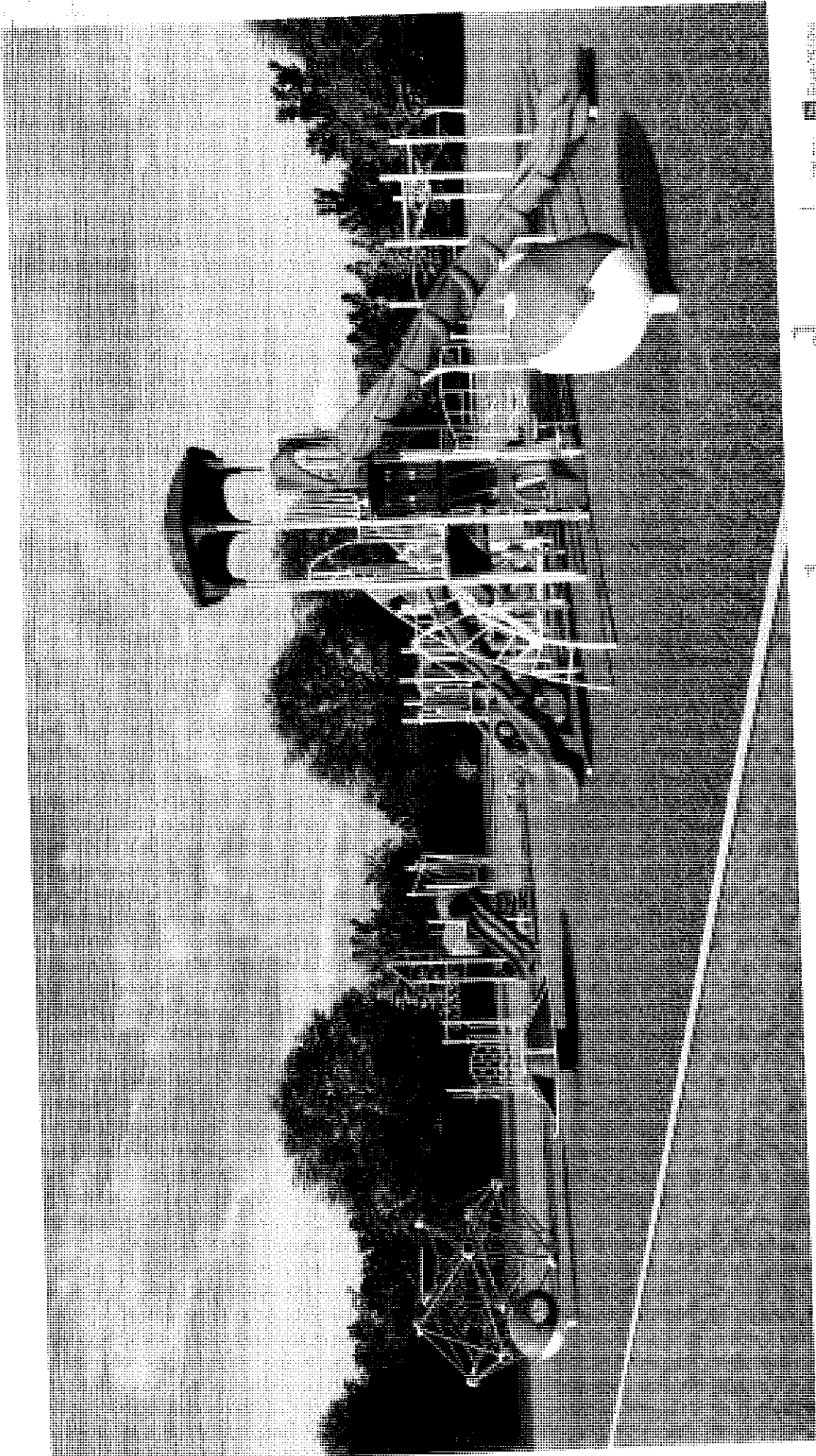

Northumberland Elementary School playground Specialists, Inc.

800.365.0075 | www.playspec.com

(New Area) - Harnsville, Virginia

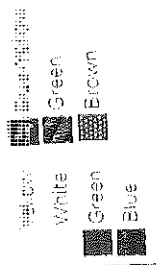

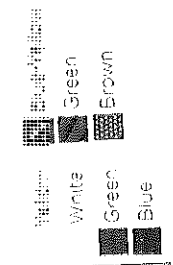

playground
Specialists Inc.

800-888-0075 | www.playsec.com

Northumberland Elementary School

(New Area) - Hartsville, Virginia



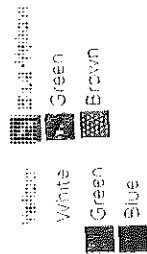
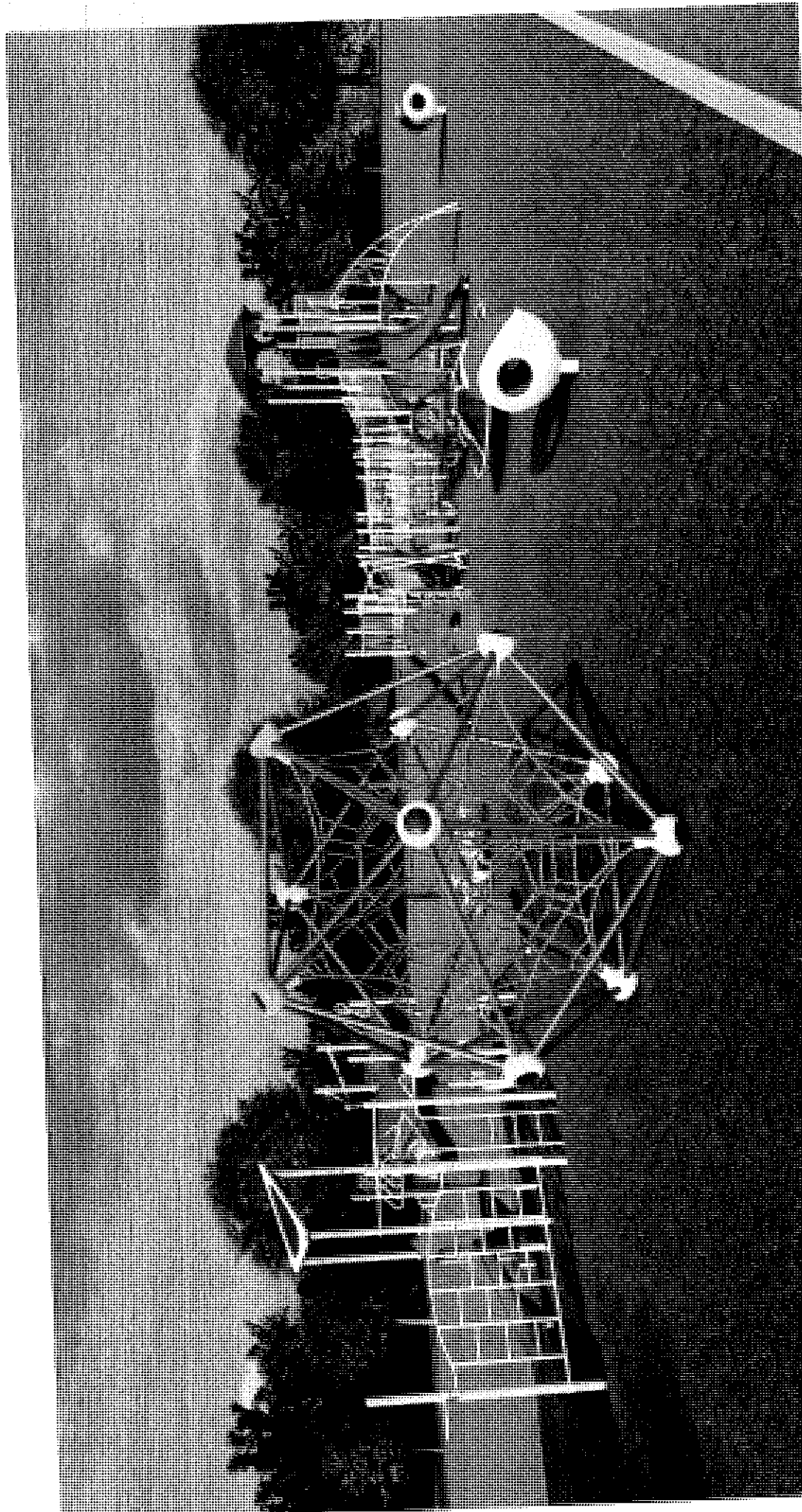

Northumberland Elementary School playground Specialists, Inc.

800.385.0075 | www.playspec.com

Northumberland Elementary School
(New Area) - Hartsville, Virginia



PLAYGROUND

playground
Specialists Inc.

800.885.0075 | www.playssci.com

Yellow
White
Green
Brown

Green
Blue

Northumberland Elementary School
(New Area) - Hartsville, Virginia

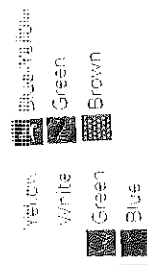
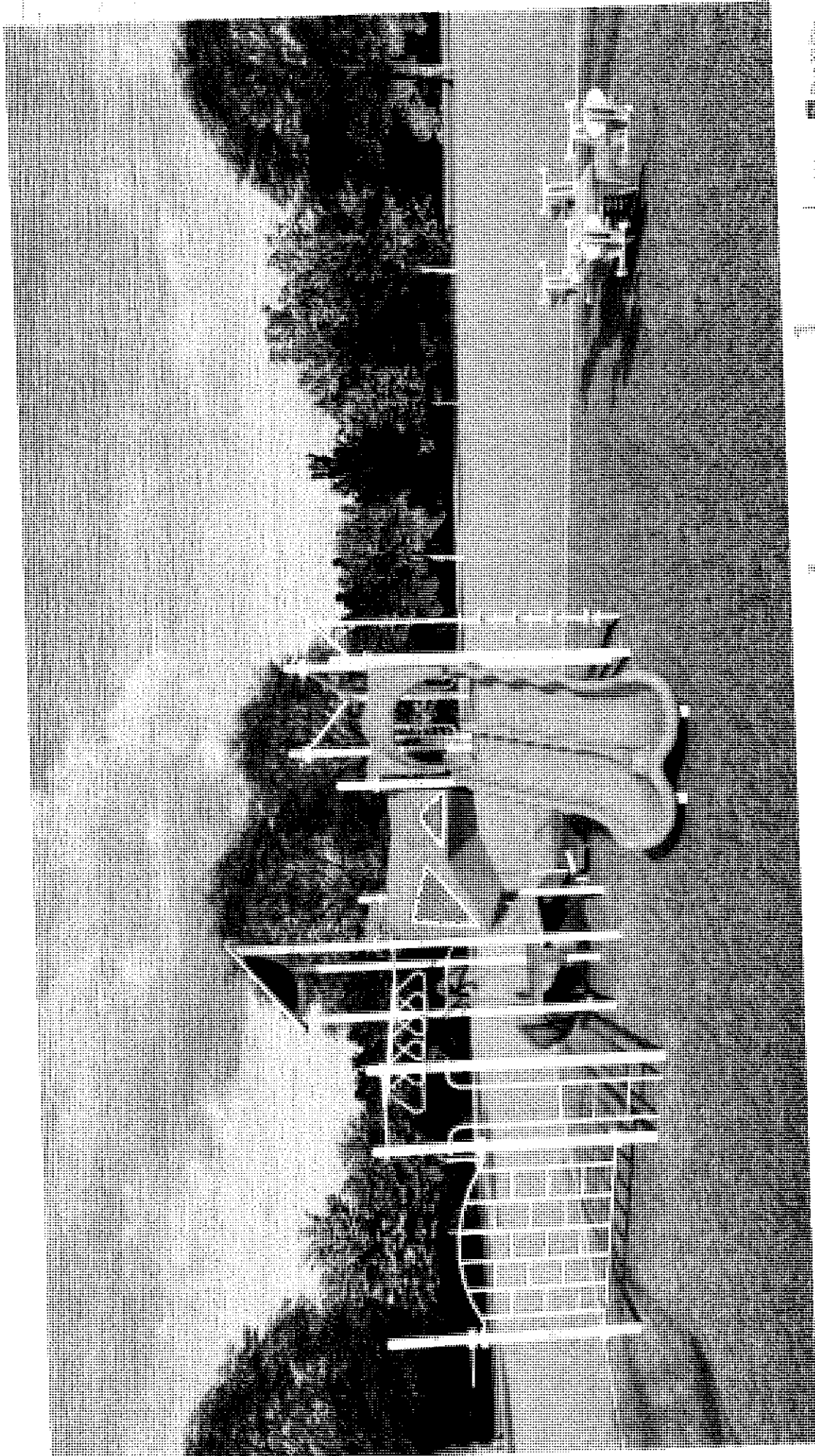

playground
Specialists Inc.

800.365.0075 | www.playsspec.com

Northumberland Elementary School
New Area - Harrisville, Virginia

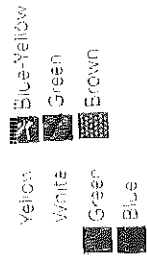

playground
Specialists, Inc.

800.385.0075 | www.pla.scec.com

Northumberland Elementary School

(New Area) - Hartsville, Virginia

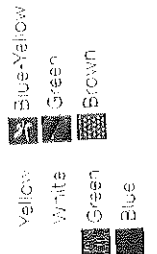
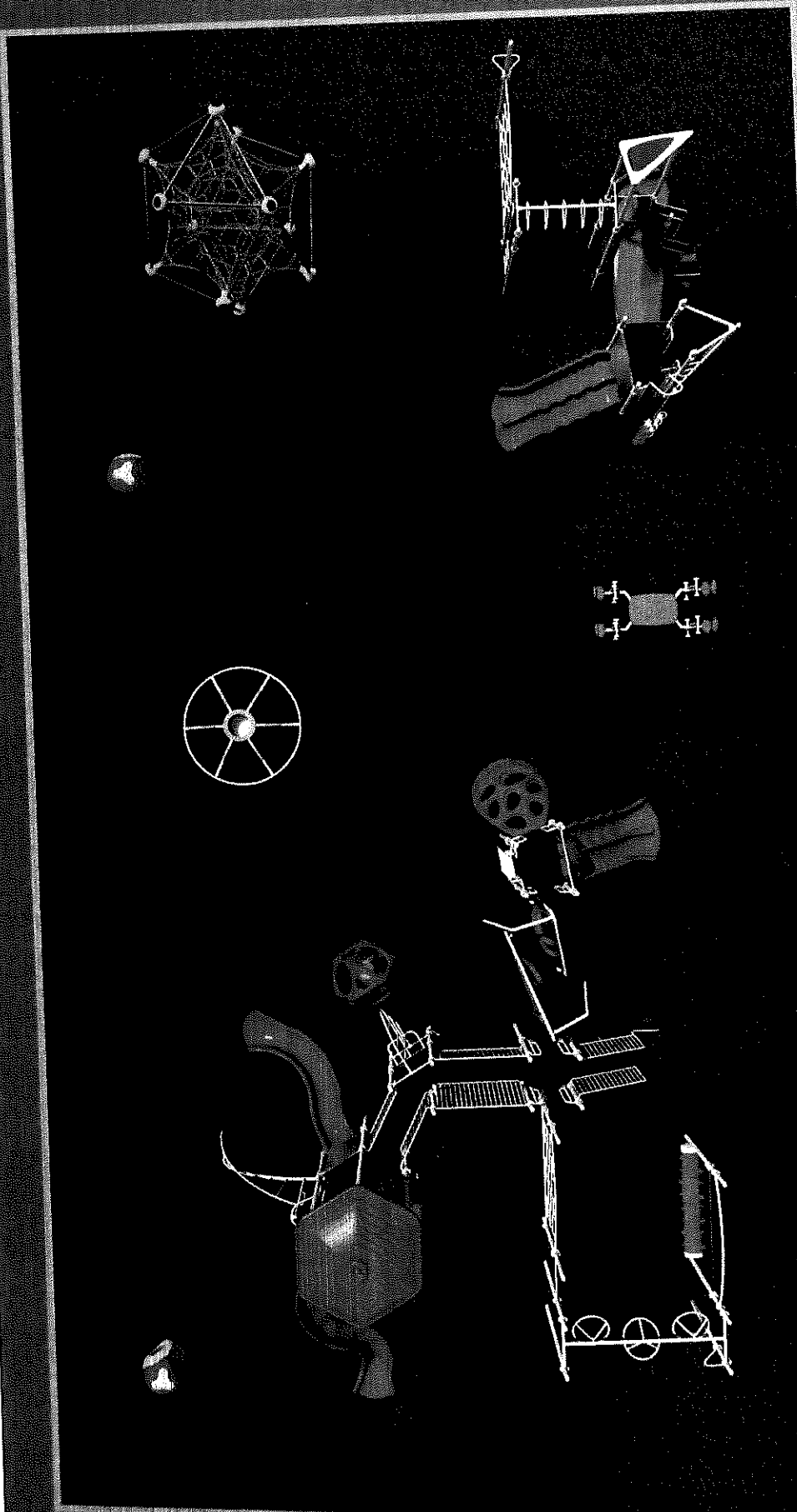

playground
Specialists Inc

800.885.0075 | www.playsspc.com

Northumberland Elementary School
(New Area) - Hartsville, Virginia

playground
Specialists Inc.

29 APPLES CHURCH ROAD
THURMONT MD 21788
800-385-0075
WWW.PLAYSPEC.COM

Northumberland Elementary (New Area)

Heathsville, Virginia

EQUIPMENT SIZE
X' x Y' x Z'

USE ZONE
X' x Y'

PERIMETER:
324 FL.

AREX:
5515 Sq.ft.

FALL HEIGHT:
9 FL

USER CAPACITY:
122

AGE GROUP:
2-12

- ✓ ASTM F1487-21
- ✓ CPSC #325



PROJECT NO:
P111323-10A

SCALE:
3/32"=1'-0"

DRAWN BY:
LMARKER

Paper Size

B

DATE:
13-NOV-23

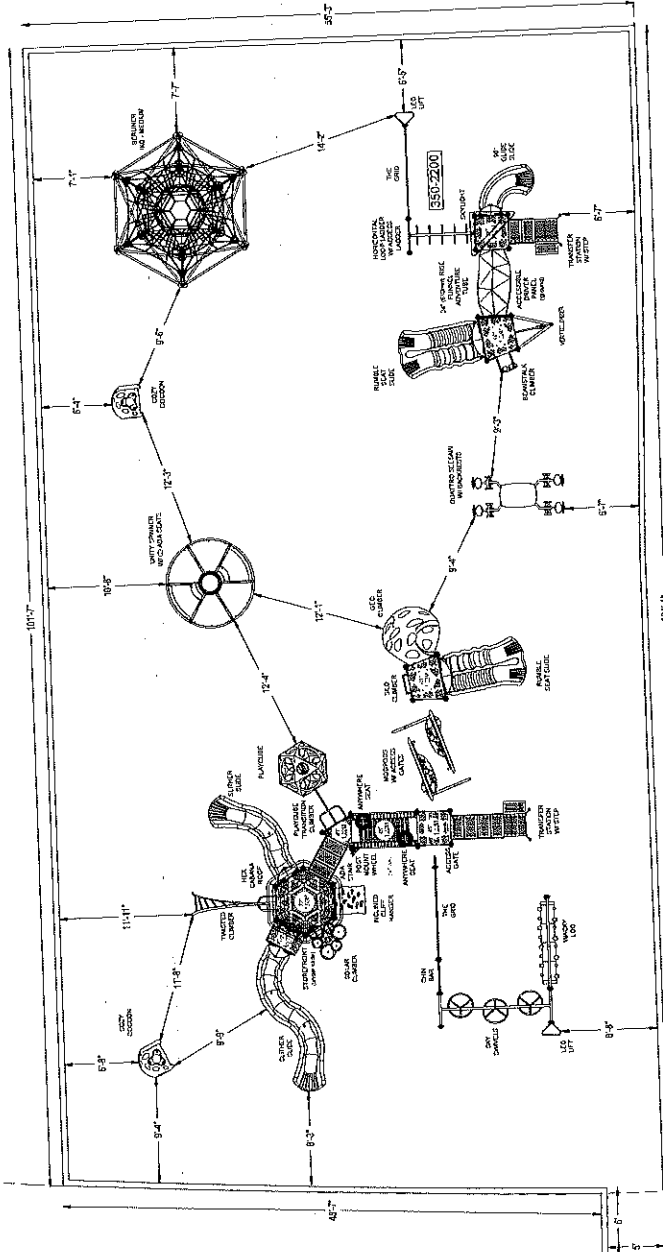

PLAYGROUND SUPERVISION REQUIRED

Northumberland County Draft Capital Improvement Program Project Form

<p>(1) Office/Department: NCPS Maintenance Department</p>	
<p>(2) Project Title Urgent Necessary Desirable</p> <p style="text-align: center;">Project Priority: Necessary Year Required: 2024</p>	
<p>(3) Project Description (include sketches, appraisals, plans, etc.) Replacement of failing outer perimeter security fence at the NCPS Bus Garage.</p> <p>Attachment #</p>	
<p>(4) Project Justification (includes ramifications if project is not implemented) The back end of the property line is not secure due to the security fence collapsing. All supporting poles are deteriorating past the point of repair and all existing fencing material shows signs of heavy rust. The forward section of this fence line where the entry and exit points are have been repaired numerous times over its lifespan. An updated fencing system will provide adequate security for this location, preventing fuel theft as well as a secure location for all buses and fleet vehicles.</p> <p>Attachment # <u>Estimate 3498 from Northern Neck Service Group LLC.pdf</u></p>	
<p>(5) Cost (include staffing needs, annual O&M requirements, planning/engineering, equipment/furniture, acquisition, construction)\$39,925</p>	
<p>(6) Funding Source(s)</p> <p>Current Revenue Grant (Type) Revenue Bond Loan (Type) General Obligation Bond Special Assessment Capital Reserve Fund Other</p>	

Requestor Date

Planning Commission Meeting

Date/Time

Planning Commission Comments:

Northern Neck Service Group, LLC
 215 Chesapeake Dr.
 White Stone, VA 22578
 Frederickj66@yahoo.com



Estimate

ESTIMATE # 3498
 DATE 01/29/2023

ADDRESS
 Jeffrey Brann
 201 Academic Lane
 Heathsville, Va 22473

PROJECT/PURCHASE ORDER
 Bus Garage fence

DATE	ACTIVITY	QTY	AMOUNT
	Fence-chainlink Install approximately 1400' of 6' high galvanized chain-link with 1' of three strand barb wire. 9 gage mesh with 2"-line posts and 2 1/2" terminal posts. Include a bottom tension for additional security. Terminal points and three double gate access with be the same as existing.	1	34,300.00
	Fence Demo Demo and haul existing fence, recycling dumpsters will be provided by the county. All post will be cut to grade to eliminate further erosion.	1	5,625.00
	Fence Disclaimer Northern Neck Fence Company is fully licensed and insured. NNFC is responsible for identifying all public utilities with MISS Utility of Virginia. Property owner is responsible for identifying all private underground pipes, lines, cables wires, septic, conduit etc. Any damage to these "private" utilities will be responsibility of the property owner. Property owner is responsible for accurate property line identification and assumes responsibility for property lines. *** Estimates only valid for 10 days***	1	0.00

Check us out on Facebook or online!
www.nnseamlessgutters.com
www.nnfencecompany.com



TOTAL \$39,925.00

Accepted By

Accepted Date

Payment Due Upon Completion

Northumberland County Draft Capital Improvement Program Project Form

<p>(1) Office/Department NCPS Maintenance Department</p>	
<p>(2) Project Title Urgent Necessary Desirable</p> <p style="text-align: center;">Project Priority Necessary Year Required 2024</p>	
<p>(3) Project Description (include sketches, appraisals, plans, etc.) NMS Gym Floor Resurfacing. This includes sanding down to bare wood slats, the application of new graphics, official line markings and school color borders. A new protective screen coat will be applied to ensure the longevity of this work.</p> <p>Attachment #</p>	
<p>(4) Project Justification (includes ramifications if project is not implemented) The current screening on the NMS gym floor is no longer serviceable and all graphics have significant damage. As per VHSL regulations all 3 point, foul, and volleyball markings must be a neutral color and ours are yellow which makes it extremely difficult for officials to read during athletic events. The current flow is a pine slat floating floor that needs a protective screen coat to ensure a proper moisture barrier.</p> <p>Attachment #  img20231102_14481346.pdf  img20231102_14570540.pdf  img20231102_14584515.pdf</p>	
<p>(5) Cost (include staffing needs, annual O&M requirements, planning/engineering, equipment/furniture, acquisition, construction) \$17,645.00</p>	
<p>(6) Funding Source(s)</p> <p>Current Revenue Grant (Type) Revenue Bond Loan (Type) General Obligation Bond Special Assessment Capital Reserve Fund Other</p>	

Requestor Date

Planning Commission Meeting

Date/Time

Planning Commission Comments:

ProSource Incorporated of Virginia

P. O. Box 366
Fieldale, VA 24089-0366
Office: (276) 252-5292
Fax: (276) 622-2215
psiofva82@gmail.com
www.prosourceincofva.com

Quote

Date
11/2/23

Quote For:
Northumberland County Public Schools
ATTENTION: Jeff Brann jbrann@nucps.net

GYM FLOOR SANDING QUOTE FOR
Northumberland Middle School

Job Description	Total
<p>We will furnish all labor & materials necessary to sand, clean and seal gym floor. Once seal dries, we will layout & paint 2" main basketball court lines, 2" main volleyball court lines, 2 ft. border with NORTHUMBERLAND inside the border on both ends of the floor (bare wood letters) and stain inside the 3 point line. We will also layout & paint the large N inside the center circle. Once all paint is dry we will apply 2 coats of oil modified finish to gym floor.</p> <p>PLEASE NOTE THAT PRICING IS BASED ON THE ATTACHED GYM FLOOR LAYOUT & DETAIL SHEET SHOWING COLORS, SIZE OF LETTERING, ETC. ANY CHANGES TO THE LAYOUT COULD RESULT IN A PRICE CHANGE.</p>	\$17,645.00
Total	

Northumberland County Draft Capital Improvement Program Project Form

<p>(1) Office/Department: NCPs Maintenance Department</p>	
<p>(2) Project Title Urgent Necessary Desirable</p> <p style="text-align: center;">Project Priority: Necessary Year Required: 2024</p>	
<p>(3) Project Description (include sketches, appraisals, plans, etc.) Replacement Service Truck with Snow Plow Capabilities</p> <p>Attachment #</p>	
<p>(4) Project Justification (includes ramifications if project is not implemented) The current service truck has an excessive amount of miles and is becoming very costly to maintain. The school system relies on this truck heavily for snow plowing and salting of the parking lots and bus loops.</p> <p>Attachment # 20231101143348734.pdf SKM 4050i23102413220.pdf</p>	
<p>(5) Cost (include staffing needs, annual O&M requirements, planning/engineering, equipment/furniture, acquisition, construction)\$60,165</p>	
<p>(6) Funding Source(s)</p> <p>Current Revenue Grant (Type) Revenue Bond Loan (Type) General Obligation Bond Special Assessment Capital Reserve Fund Other</p>	

Requestor Date

Planning Commission Meeting

Date/Time

Planning Commission Comments:

Prepared for: Mr. JEFFREY BRANN, DIRECTOR OF FACILITIES MAINTENANCE, NORTHUMBERLAND
COUNTY PUBLICSCHOOLS

2022 F-250 4x4 SD Regular Cab 8' box 142" WB SRW XL (F2B)
Price Level: 280

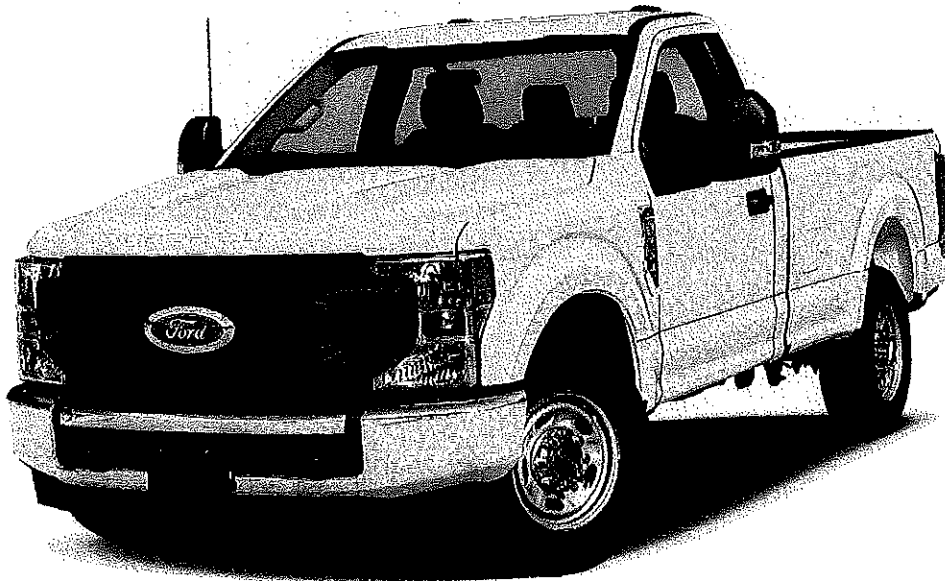

Client Proposal

Prepared by:
Raymond Bunch
Office: 804-232-3492
Email: rbunch@colonialtruck.com
Quote ID: NORTH-1
Date: 01/27/2023



Prepared for: Mr. JEFFREY BRANN
 DIRECTOR OF FACILITIES MAINTENANCE, NORTHUMBERLAND COUNTY

PUBLIC SCHOOLS
 Prepared by: Raymond Bunch
 01/27/2023

Colonial Ford Truck Sales, Inc. | 1833 Commerce Richmond Virginia | 232247801

2022 F-250 4x4 SD Regular Cab 8' box 142" WB SRW XL (F2B)

Price Level: 280 | Quote ID: NORTH-1

Warranty

Standard Warranty

<i>Basic Warranty</i>	36 months/36,000 miles
Basic warranty	
<i>Powertrain Warranty</i>	60 months/60,000 miles
Powertrain warranty	
<i>Corrosion Perforation</i>	60 months/unlimited
Corrosion perforation warranty	
<i>Roadside Assistance Warranty</i>	60 months/60,000 miles
Roadside warranty	



Prepared for: Mr. JEFFREY BRANN

DIRECTOR OF FACILITIES MAINTENANCE, NORTHUMBERLAND COUNTY

Prepared by: Raymond Bunch

01/27/2023

Colonial Ford Truck Sales, Inc. | 1833 Commerce Richmond Virginia | 232247801

2022 F-250 4x4 SD Regular Cab 8' box 142" WB SRW XL (F2B)

Price Level: 280 | Quote ID: NORTH-1

As Configured Vehicle

Code	Description	MSRP
Base Vehicle		
F2B	Base Vehicle Price (F2B)	\$43,235.00
Packages		
600A	Order Code 600A <i>Includes:</i> - Engine: 6.2L 2-Valve SOHC EFI NA V8 Flex-Fuel - Transmission: TorqShift-G 6-Spd Auto w/SelectShift - GVWR: 10,000 lb Payload Package - Wheels: 17" Argent Painted Steel Includes painted hub covers/center ornaments. - HD Vinyl 40/20/40 Split Bench Seat Includes center armrest, cupholder, storage and driver's side manual lumbar. - Radio: AM/FM Stereo w/MP3 Player Includes 4 speakers. - SYNC Communications & Entertainment System Includes enhanced voice recognition with 911 Assist, 4.2" LCD center stack screen, Applink and 1 smart-charging USB-C port.	N/C
Powertrain		
996	Engine: 6.2L 2-Valve SOHC EFI NA V8 Flex-Fuel	Included
44S	Transmission: TorqShift-G 6-Spd Auto w/SelectShift	Included
X3E	Electronic-Locking w/3.73 Axle Ratio	\$430.00
STDGV	GVWR: 10,000 lb Payload Package	Included
Wheels & Tires		
TBM	Tires: LT245/75R17E BSW A/T <i>Spare may not be the same as road tire.</i>	\$165.00
64A	Wheels: 17" Argent Painted Steel <i>Includes painted hub covers/center ornaments.</i>	Included
Seats & Seat Trim		
A	HD Vinyl 40/20/40 Split Bench Seat <i>Includes center armrest, cupholder, storage and driver's side manual lumbar.</i>	Included
Other Options		



Prepared for: **Mr. JEFFREY BRANN**
 DIRECTOR OF FACILITIES MAINTENANCE, NORTHUMBERLAND COUNTY

BUBLICSCHOOLS
 Prepared by: Raymond Bunch
 01/27/2023

Colonial Ford Truck Sales, Inc. | 1833 Commerce Richmond Virginia | 232247801

2022 F-250 4x4 SD Regular Cab 8' box 142" WB SRW XL (F2B)

Price Level: 280 | Quote ID: NORTH-1

As Configured Vehicle (cont'd)

Code	Description	MSRP
		STD
142WB	142" Wheelbase	STD
PAINT	Monotone Paint Application	\$395.00
96V	XL Value Package <i>Includes:</i> - Bright Chrome Hub Covers & Center Ornaments - Chrome Rear Step Bumper - Steering Wheel-Mounted Cruise Control	\$1,100.00
90L	Power Equipment Group <i>Deletes passenger-side lock cylinder. Includes upgraded door trim panel.</i> <i>Includes:</i> - Accessory Delay - Trailer Tow Mirrors w/Power Heated Glass <i>Includes manual folding, manually telescoping, heated convex spotter mirror and integrated clearance lamps and turn signals.</i> - Advanced Security Pack <i>Includes SecurILock Passive Anti-Theft System (PATS) and inclination/intrusion sensors.</i> - Power Locks - Power Tailgate Lock - Power Front Seat Windows <i>Includes 1-touch up/down driver/passenger window.</i> - Remote Keyless Entry	\$250.00
473	Snow Plow Prep Package <i>Includes computer selected springs for snowplow application. Note restrictions apply; see supplemental reference or body builders layout book for details. May result in deterioration of ride quality when vehicle is not equipped with snowplow. Dual battery (86M) recommended with 6.2L or 7.3L gasoline engines; see body builders layout book for details.</i>	-\$625.00
66D	Pickup Box Delete <i>Deletes tie-down hooks, tailgate, rearview camera, 7/4 pin connector and center high-mounted stop lamp (CHMSL) (only on vehicles over 10,000 lbs. GVWR). Incomplete vehicle package - requires further manufacture end certification by a final stage manufacturer. In addition, Ford urges manufacturers to follow the recommendations of the Ford Incomplete Vehicle Manual and the Ford Truck Body Builder's Layout Book (and applicable supplements).</i> <i>Includes:</i> - Rear Bumper Delete - Spare Wheel, Tire, Carrier & Jack Delete <i>The selection of 66D Pickup Box Delete adjusts the curb weight, but does not modify the payload. For payload information, contact your upfitter (final stage manufacturer) or review the Body Builder Advisory Service (BBAS) website (www.fordbbas.com).</i>	\$100.00
41H	Engine Block Heater	\$210.00
86M	Dual 78 AH Battery	\$300.00
52B	Trailer Brake Controller <i>Verified to be compatible with select electric over hydraulic brakes. Includes smart trailer tow connector.</i>	\$320.00
18B	Platform Running Boards	



Prepared for: Mr. JEFFREY BRANN
 DIRECTOR OF FACILITIES MAINTENANCE, NORTHUMBERLAND COUNTY

BUBLICSCHOOLS
 Prepared by: Raymond Bunch
 01/27/2023

Colonial Ford Truck Sales, Inc. | 1833 Commerce Richmond Virginia | 232247801

2022 F-250 4x4 SD Regular Cab 8' box 142" WB SRW XL (F2B)

Price Level: 280 | Quote ID: NORTH-1

As Configured Vehicle (cont'd)

Code	Description	MSRP
		N/C
153	Front License Plate Bracket <i>Standard in states requiring 2 license plates and optional to all others.</i>	\$415.00
872	Rear View Camera & Prep Kit <i>Pre-installed content includes cab wiring, frame wiring to the rear most cross member and video display with 4" display. Upfitters kit includes camera with mounting bracket, 14' jumper wire and camera mounting, aiming instructions and electrochromic mirror.</i>	\$95.00
592	LED Roof Clearance Lights	\$175.00
43C	110V/400W Outlet Requires Extra Extra Heavy-Duty Alternator (67E) when ordered with Upfitter Switches (66S) and Snow Plow Pkg. (473) or Snow Plow/Camper Pkg. (47B). <i>Includes 1 in-dash mounted outlet.</i>	
	<i>Includes:</i> - 200 Amp Alternator	\$165.00
66S	Upfitter Switches (6) Requires Extra Extra Heavy-Duty Alternator (67E) when ordered with 110V/400W Outlet (43C) and Snow Plow Pkg. (473) or Snow Plow/Camper Pkg. (47B) and 6.2L Gas engine (998); or Dual Alternators (67A) when ordered with 110V/400W Outlet (43C) and Snow Plow Pkg. (473) or Snow Plow/Camper Pkg. (47B) and Diesel engine (99T); or Dual Extra Heavy-Duty Alternator (67B) when ordered with 110V/400W Outlet (43C) and Snow Plow Pkg. (473) or Snow Plow/Camper Pkg. (47B) and 7.3L Gas engine (99N). <i>Located in overhead console.</i>	Included
587	Radio: AM/FM Stereo w/MP3 Player <i>Includes 4 speakers.</i>	
	<i>Includes:</i> - SYNC Communications & Entertainment System <i>Includes enhanced voice recognition with 911 Assist, 4.2" LCD center stack screen, AppLink and 1 smart-charging USB-C port.</i>	-\$20.00
19Z	4G LTE Wi-Fi Hotspot Removal	
Fleet Options		
942	Daytime Running Lamps (DRL) (LPO) Requires valid FIN code. <i>The non-controllable 942 Daytime Running Lamps (DRL) replace the standard Daytime Running Lamps (DRL) on/off cluster controllable.</i>	\$45.00
WARANT	Fleet Customer Powertrain Limited Warranty Requires valid FIN code.	N/C



Prepared for: Mr. JEFFREY BRANN
 DIRECTOR OF FACILITIES MAINTENANCE, NORTHUMBERLAND COUNTY

BUBLICSCHOOLS
 Prepared by: Raymond Bunch
 01/27/2023

Colonial Ford Truck Sales, Inc. | 1833 Commerce Richmond Virginia | 232247801

2022 F-250 4x4 SD Regular Cab 8' box 142" WB SRW XL (F2B)

Price Level: 280 | Quote ID: NORTH-1

As Configured Vehicle (cont'd)

Code	Description	MSRP
<p><i>Ford is increasing the 5-year 60,000-mile limited powertrain warranty to 5-years, 100,000 miles. Only Fleet purchasers with a valid Fleet Identification Number (FIN code) will receive the extended warranty. When the sale is entered into the sales reporting system with a sales type fleet along with a valid FIN code, the warranty extension will automatically be added to the vehicle. The extension will stay with the vehicle even if it is subsequently sold to a non-fleet customer before the expiration. This extension applies to both gas and diesel powertrains. Dealers can check for the warranty extension on eligible fleet vehicles in OASIS. Please refer to the Warranty and Policy Manual section 3.13.00 Gas Engine Commercial Warranty. This change will also be reflected in the printed Warranty Guided distributed with the purchase of every new vehicle.</i></p>		
Emissions		
425	50-State Emissions System	STD
Exterior Color		
Z1_01	Oxford White	N/C
Interior Color		
AS_01	Medium Earth Gray w/HD Vinyl 40/20/40 Split Bench Seat	N/C
Upfit Options		
DEJANA-10	KNAPHEIDE MODEL 696 SERVICE BODY	\$11,615.00
SUBTOTAL		\$58,370.00
Destination Charge		\$1,795.00
TOTAL		\$60,165.00



Prepared for: Mr. JEFFREY BRANN

DIRECTOR OF FACILITIES MAINTENANCE, NORTHUMBERLAND COUNTY

BUBLICSCHOOLS
Prepared by: Raymond Bunch

Colonial Ford Truck Sales, Inc. | 1833 Commerce Richmond Virginia | 232247801

01/27/2023
2022 F-250 4x4 SD Regular Cab 8' box 142" WB SRW XL (F2B)

Price Level: 280 | Quote ID: NORTH-1

Pricing Summary - Single Vehicle

	MSRP
<i>Vehicle Pricing</i>	\$43,235.00
Base Vehicle Price	\$3,520.00
Options	\$0.00
Colors	\$11,615.00
Upfitting	\$0.00
Fleet Discount	\$0.00
Fuel Charge	\$1,795.00
Destination Charge	\$60,165.00
Subtotal	

Pre-Tax Adjustments

Code	Description	MSRP
DISCOUNT	DISCOUNT	-\$9,665.00
Total		\$50,500.00

Customer Signature

Acceptance Date

Prepared for: Mr. DAVID AMBROSE, NORTHUMBERLAND COUNTY PUBLIC SCHOOLS

2023 F-350 4x4 SD Crew Cab 8' box 176" WB SRW XL (W3B)
Price Level: 350

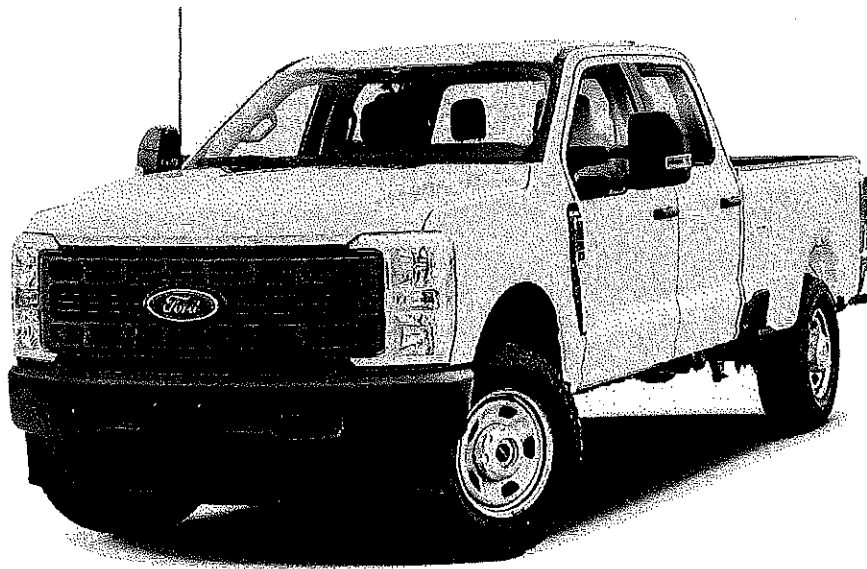

Client Proposal

Prepared by:
Raymond Bunch
Office: 804-232-3492
Email: rbunch@colonialtruck.com
Quote ID: NCPS-1
Date: 11/01/2023



Colonial Ford Truck Sales, Inc. | 1833 Commerce, Richmond, Virginia, 232247801
Office: 804-232-3492 | Fax: 804-230-1932

Prepared for: Mr. DAVID AMBROSE
NORTHUMBERLAND COUNTY PUBLIC SCHOOLS
Prepared by: Raymond Bunch
11/01/2023



Colonial Ford Truck Sales, Inc. | 1833 Commerce Richmond Virginia | 232247801

2023 F-350 4x4 SD Crew Cab 8' box 176" WB SRW XL (W3B)

Price Level: 350 | Quote ID: NCPS-1

Warranty

Standard Warranty

<i>Basic Warranty</i>	
Basic warranty	36 months/36,000 miles
<i>Powertrain Warranty</i>	
Powertrain warranty	60 months/60,000 miles
<i>Corrosion Perforation</i>	
Corrosion perforation warranty	60 months/unlimited
<i>Roadside Assistance Warranty</i>	
Roadside warranty	60 months/60,000 miles

Prices and content availability as shown are subject to change and should be treated as estimates only. Actual base vehicle, package and option pricing may vary from this estimate because of special local pricing, availability or pricing adjustments not reflected in the dealer's computer system. See salesperson for the most current information.

Prepared for: Mr. DAVID AMBROSE
 NORTHUMBERLAND COUNTY PUBLIC SCHOOLS
 Prepared by: Raymond Bunch
 11/01/2023



Colonial Ford Truck Sales, Inc. | 1833 Commerce Richmond Virginia | 232247801

2023 F-350 4x4 SD Crew Cab 8' box 176" WB SRW XL (W3B)

Price Level: 350 | Quote ID: NCPS-1

As Configured Vehicle

Code	Description	MSRP
Base Vehicle		
W3B	Base Vehicle Price (W3B)	\$51,815.00
Packages		
610A	Order Code 610A <i>Includes:</i> - Engine: 6.8L 2V DEVCT NA PFI V8 Gas - Transmission: TorqShift-G 10-Speed Automatic <i>Includes SelectShift and selectable drive modes: normal, eco, slippery roads, tow/haul and off-road.</i> - GVWR: 10,900 lb Payload Package - Wheels: 17" Argent Painted Steel <i>Includes painted hub covers/center ornaments.</i> - HD Vinyl 40/20/40 Split Bench Seat <i>Includes center armrest, cupholder, storage and driver's side manual lumbar.</i> - Radio: AM/FM Stereo w/MP3 Player <i>Includes 4 speakers.</i> - SYNC 4 <i>Includes 8" LCD capacitive touchscreen with swipe capability, wireless phone connection, cloud connected, Applink with app catalog, 911 Assist, Apple CarPlay and Android Auto compatibility and digital owner's manual.</i>	N/C
Powertrain		
99A	Engine: 6.8L 2V DEVCT NA PFI V8 Gas	Included
44F	Transmission: TorqShift-G 10-Speed Automatic <i>Includes SelectShift and selectable drive modes: normal, eco, slippery roads, tow/haul and off-road.</i>	Included
X3E	Electronic-Locking w/3.73 Axle Ratio	\$430.00
STDGV	GVWR: 10,900 lb Payload Package	Included
Wheels & Tires		
TBM	Tires: LT245/75R17E BSW A/T (4) <i>Spare may not be the same as road tire.</i>	\$165.00
64A	Wheels: 17" Argent Painted Steel <i>Includes painted hub covers/center ornaments.</i>	Included
Seats & Seat Trim		
A	HD Vinyl 40/20/40 Split Bench Seat <i>Includes center armrest, cupholder, storage and driver's side manual lumbar.</i>	Included

Prices and content availability as shown are subject to change and should be treated as estimates only. Actual base vehicle, package and option pricing may vary from this estimate because of special local pricing, availability or pricing adjustments not reflected in the dealer's computer system. See salesperson for the most current information.

Prepared for: Mr. DAVID AMBROSE
 NORTHUMBERLAND COUNTY PUBLIC SCHOOLS



Prepared by: Raymond Bunch
 11/01/2023

Colonial Ford Truck Sales, Inc. | 1833 Commerce Richmond Virginia | 232247801

2023 F-350 4x4 SD Crew Cab 8' box 176" WB SRW XL (W3B)

Price Level: 350 | Quote ID: NCP5-1

As Configured Vehicle (cont'd)

Code	Description	MSRP
Other Options		
		STD
176WB	176" Wheelbase	
		STD
PAINT	Monotone Paint Application	Included
587	Radio: AM/FM Stereo w/MP3 Player <i>Includes 4 speakers.</i>	
	<i>Includes: - SYNC 4 Includes 8" LCD capacitive touchscreen with swipe capability, wireless phone connection, cloud connected, AppLink with app catalog, 911 Assist, Apple CarPlay and Android Auto compatibility and digital owner's manual.</i>	
		\$250.00
473	Snow Plow Prep Package Requires 250 Amp Alternator (67E) or 410 Amp Dual Alternator (67B) when ordered with Upfitter Switches (66S) and 120V/400W Outlet (43C). <i>Includes computer selected springs for snowplow application. Note: restrictions apply; see supplemental reference or body builders layout book for details. May result in deterioration of ride quality when vehicle is not equipped with snowplow. Dual battery (66M) recommended with 6.8L or 7.3L gasoline engines; see body builders layout book for details.</i>	
		\$85.00
67E	250 Amp Alternator (Gas)	\$445.00
18B	Platform Running Boards	\$95.00
592	LED Roof Clearance Lights	\$165.00
66S	Upfitter Switches (6) <i>Located in overhead console.</i>	
Fleet Options		
		N/C
WARANT	Fleet Customer Powertrain Limited Warranty Requires valid FIN code. <i>Ford is increasing the 5-year 60,000-mile limited powertrain warranty to 5-years, 100,000 miles. Only Fleet purchasers with a valid Fleet Identification Number (FIN code) will receive the extended warranty. When the sale is entered into the sales reporting system with a sales type fleet along with a valid FIN code, the warranty extension will automatically be added to the vehicle. The extension will stay with the vehicle even if it is subsequently sold to a non-fleet customer before the expiration. This extension applies to both gas and diesel powertrains. Dealers can check for the warranty extension on eligible fleet vehicles in OASIS. Please refer to the Warranty and Policy Manual section 3.13.00 Gas Engine Commercial Warranty. This change will also be reflected in the printed Warranty Guided distributed with the purchase of every new vehicle.</i>	
Emissions		
425	50-State Emissions System	STD

Prices and content availability as shown are subject to change and should be treated as estimates only. Actual base vehicle, package and option pricing may vary from this estimate because of special local pricing, availability or pricing adjustments not reflected in the dealer's computer system. See salesperson for the most current information.

Prepared for: **Mr. DAVID AMBROSE**
 NORTHUMBERLAND COUNTY PUBLIC SCHOOLS
 Prepared by: Raymond Bunch
 11/01/2023



Colonial Ford Truck Sales, Inc. | 1833 Commerce Richmond Virginia | 232247801

2023 F-350 4x4 SD Crew Cab 8' box 176" WB SRW XL (W3B)

Price Level: 350 | Quote ID: NCPS-1

As Configured Vehicle (cont'd)

Code	Description	MSRP
Exterior Color		
Z1_01	Oxford White	N/C
Interior Color		
AS_03	Medium Dark Slate w/HD Vinyl 40/20/40 Split Bench Seat	N/C
SUBTOTAL		\$53,450.00
Destination Charge		\$1,995.00
TOTAL		\$55,445.00

Prices and content availability as shown are subject to change and should be treated as estimates only. Actual base vehicle, package and option pricing may vary from this estimate because of special local pricing, availability or pricing adjustments not reflected in the dealer's computer system. See salesperson for the most current information.

Prepared for: **Mr. DAVID AMBROSE**
 NORTHUMBERLAND COUNTY PUBLIC SCHOOLS
 Prepared by: Raymond Bunch
 11/01/2023



Colonial Ford Truck Sales, Inc. | 1833 Commerce Richmond Virginia | 232247801

2023 F-350 4x4 SD Crew Cab 8' box 176" WB SRW XL (W3B)

Price Level: 350 | Quote ID: NCPS-1

Pricing Summary - Single Vehicle

	MSRP
<i>Vehicle Pricing</i>	
Base Vehicle Price	\$51,815.00
Options	\$1,635.00
Colors	\$0.00
Upfitting	\$0.00
Fleet Discount	\$0.00
Fuel Charge	\$0.00
Destination Charge	\$1,995.00
Subtotal	\$55,445.00

Pre-Tax Adjustments

Code	Description	MSRP
DISCOUNT	DISCOUNT	-\$5,559.36
Total		\$49,885.64

Customer Signature

Acceptance Date

Prices and content availability as shown are subject to change and should be treated as estimates only. Actual base vehicle, package and option pricing may vary from this estimate because of special local pricing, availability or pricing adjustments not reflected in the dealer's computer system. See salesperson for the most current information.



Purchase Agreement

Marco Verdone
 Richmond Ford Lincoln
 4600 W Broad St
 Richmond, VA 23230

Buyer	Co-Buyer	Vehicle
Jeff Brann C: (804) 580-0754 jbrann@nucps.net		2023 Ford Super Duty F-250 SRW XL VIN: 1FT8X2BA9PEE21843 Stock #: L231210 Mileage: 5 Color:

Customer Trade							
	Year	Make	Model	VIN	Engine	Mileage	Payoff
0	0						\$0.00

Term	Cash Down		
	0.00	0.00	0.00
	Payments		
0	\$56,427 to \$56,447	\$56,427 to \$56,447	\$56,427 to \$56,447

Purchase Details	
Retail Price:	\$54,485.00
Sales Price:	\$53,205.00
Savings:	\$1,280.00
Accessories:	\$0.00
Government Fees:	\$74.75
Processing Fee:	\$799.00
Total Taxes:	\$2,347.58
Total Sales Price:	\$56,426.33
Trade Allowance:	\$0.00
Trade Payoff:	\$0.00
Trade Equity:	\$0.00
Rebate:	\$0.00
Cash Down:	\$0.00
Amount Financed:	\$56,426.33

X

 Customer Signature

X

 Manager Signature

 Date

 Date

Disclaimer:

Printed 10/24/23 2:26 PM

With approved credit. Plus taxes, license, tags and \$799 processing fee. May require FMCC/LASF financing.

Northumberland County Draft Capital Improvement Program Project Form

<p>(1) Office/Department: NCPS Maintenance Department</p>	
<p>(2) Project Title Urgent Necessary Desirable</p> <p style="text-align: center;">Project Priority: Necessary Year Required: 2026</p>	
<p>(3) Project Description (include sketches, appraisals, plans, etc.) The replacement of all NMS/NHS Roof Top Units(RTU's). Each RTU is in its 13th year of an average 15 year service life. This facility has a total of 13 RTU's and the Maintenance Department recommends a gradual replacement of four units per year. The prioritization of the order of replacement will be based off of each RTU's machinery history.</p> <p>Attachment #</p>	
<p>(4) Project Justification (includes ramifications if project is not implemented) These RTU's are gradually drawing near to the end of their service life. As the operational hours continue to increase the operating cost of each of these units will increase as well. Also, these units operate using R22 refrigerant, a refrigerant that is getting increasingly hard to find and is not covered under the Honeywell contract.</p> <p>Attachment # <u>RTU-Propane Boiler quotes.pdf</u></p>	
<p>(5) Cost (include staffing needs, annual O&M requirements, planning/engineering, equipment/furniture, acquisition, construction) As per the Honeywell's quoted price in the attachment, two Rooftop units needed to replace the units on each gym(which are in most need of replacement) will cost approximately \$450,000. These are our two largest units so the cost for replacing others would be less. The maintenance department recommends replacing two per year. This would assist with keeping the annual cost down, prevent any unneeded growth work due to the size of the project, and still keep us on a change-out cycle that falls within the life expectancy of the units currently in operation.</p>	
<p>(6) Funding Source(s)</p> <p>Current Revenue Grant (Type) Revenue Bond Loan (Type) General Obligation Bond Special Assessment Capital Reserve Fund Other</p>	

Requestor Date

Planning Commission Meeting

Date/Time

Planning Commission Comments:



Jeffrey Brann <jbrann@nucps.net>

CIP numbers

1 message

Coleburn, Joyce (VA50) <Joyce.Coleburn@honeywell.com>

Fri, Jan 27, 2023 at 4:26 PM

To: "jbrann@nucps.net" <jbrann@nucps.net>

Cc: "Hall, R E" <R.Hall@honeywell.com>

Jeff,

These are just BUDGET numbers:

PRICE PER ROOFTOP UNIT.

The RTUs over the Gym would be approx.. \$450K

The Propane Boilers at the Elementary School would be approx.. \$210K

Hope this helps!

PRICE FOR BOTH COMBINED.

Thanks

Joyce

Joyce A. Coleburn

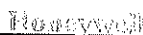



Sr Account Manager

3951 Wasterre Parkway, Suite 350

Richmond, VA 23233

434-298-7443

Northumberland County Draft Capital Improvement Program Project Form

<p>(1) Office/Department NCPS Maintenance Department</p>	
<p>(2) Project Title Urgent Necessary Desirable</p> <p style="text-align: center;">Project Priority Necessary Year Required 2024</p>	
<p>(3) Project Description (include sketches, appraisals, plans, etc.) NMS Gym Floor Resurfacing. This includes sanding down to bare wood slats, the application of new graphics, official line markings and school color borders. A new protective screen coat will be applied to ensure the longevity of this work.</p> <p>Attachment #</p>	
<p>(4) Project Justification (includes ramifications if project is not implemented) The current screening on the NMS gym floor is no longer serviceable and all graphics have significant damage. As per VHSL regulations all 3 point, foul, and volleyball markings must be a neutral color and ours are yellow which makes it extremely difficult for officials to read during athletic events. The current flow is a pine slat floating floor that needs a protective screen coat to ensure a proper moisture barrier.</p> <p>Attachment #  img20231102_14481346.pdf  img20231102_14570540.pdf  img20231102_14584515.pdf</p>	
<p>(5) Cost (include staffing needs, annual O&M requirements, planning/engineering, equipment/furniture, acquisition, construction) \$17,645.00</p>	
<p>(6) Funding Source(s)</p> <p>Current Revenue Grant (Type) Revenue Bond Loan (Type) General Obligation Bond Special Assessment Capital Reserve Fund Other</p>	

Requestor Date

Planning Commission Meeting

Date/Time

Planning Commission Comments:

ProSource Incorporated of Virginia

P. O. Box 366
 Fieldale, VA 24089-0366
 Office: (276) 252-5292
 Fax: (276) 622-2215
 psiofva82@gmail.com
 www.prosourceincofva.com

Quote

Date
11/2/23

Quote For:
Northumberland County Public Schools
ATTENTION: Jeff Brann jbrann@nucps.net

GYM FLOOR SANDING QUOTE FOR
 Northumberland Middle School

Job Description	Total
<p>We will furnish all labor & materials necessary to sand, clean and seal gym floor. Once seal dries, we will layout & paint 2" main basketball court lines, 2" main volleyball court lines, 2 ft. border with NORTHUMBERLAND inside the border on both ends of the floor (bare wood letters) and stain inside the 3 point line. We will also layout & paint the large N inside the center circle. Once all paint is dry we will apply 2 coats of oil modified finish to gym floor.</p> <p>PLEASE NOTE THAT PRICING IS BASED ON THE ATTACHED GYM FLOOR LAYOUT & DETAIL SHEET SHOWING COLORS, SIZE OF LETTERING, ETC. ANY CHANGES TO THE LAYOUT COULD RESULT IN A PRICE CHANGE.</p>	<p>\$17,645.00</p>
<p>Total</p>	